

CLOOS

QIROX COMPACT SYSTEMS

Your customised solution for
automated welding of medium-
sized and complex workpieces



CONNECT WITH US!

CONTENTS

Abiout CLOOS	4	QIROX Operating System	28
Key facts	5	Workpiece positioners	29
Advantages	6	QINEO NexT Premium	30
Modular design	7	Wire feed distance	31
Overview	8	Safety technology	32
QR-CS-1	9	Options	33
QR-CS-2	11	References	38
QR-CS-3	13	Service	44
QR-CS-4	15	CLOOS worldwide	46
QR-CS-5	17		
QR-CS-6	19		
QR-CS-7	21		
Comparison of QIROX Compact systems	23		
Basic equipment	24		
QIROX robot mechanics WL series	26		
QIROX QC2 Master	27		



WE CREATE CONNECTIONS

The CLOOS Group is an international company with its headquarters in Haiger. With over 1000 employees worldwide, CLOOS supplies welding know-how for industrial applications with the highest demands on durability and quality in efficiency-driven industries

As a global product and solution brand, CLOOS combines specialised knowledge from welding applications, robotics, automation and software in customised solutions for medium-sized companies as well as for large international automotive, commercial vehicle and agricultural machinery manufacturers

In doing so, CLOOS not only provides the decisive technical production advantage in order to produce competitively in the long term, but also faces the challenges of tomorrow as a problem solver together with its customers today.

With 10 production sites and more than 60 sales and service centres worldwide - including North and South America, Asia and Australia - customers worldwide rely on solutions from CLOOS.

ABOUT CLOOS

KEY FACTS

CLOOS in facts and figures

More than
100 years
of experience
(founded: 1919)

Engineered in
GERMANY
(Headquarters in Haiger,
Germany)

1,000 employees
(550 employees in
Germany)

10
Production sites on 3
continents

229 million €
Group revenue
(2023)

85%
International sales

>>> 4

90%
Vertical integration



YOUR CUSTOMISED SOLUTION

for automated welding of medium-sized and complex workpieces

In order to achieve optimum and economic welding of any workpiece, CLOOS has developed an extensive range of compact robot systems. They do not require much space and can be easily integrated into any production. From sensors to controller each compact system is a tailor-made unit with components which match each other perfectly.

With their variety of welding processes, extensive options and complementary services, we can offer you the perfect solution for all requirements of automated welding production.

- > Compact: Just integrate the systems into your production – the compact design saves production area.
- > User-friendly: Use our comfortable operating panels – we guarantee easy, precise and intuitive handling.
- > Reliable: Count on "Made in Germany" – as technology leader we guarantee maximum performance in proven CLOOS quality.
- > Flexible: Realise individual extensions and retrofits – the modular design makes it possible.
- > Time-saving: Benefit from easy assembly and maintenance – our compact systems are completely pre-installed electrically and mechanically.





MODULAR DESIGN CREATES A MULTI-TUDE OF POSSIBILITIES

Our QIROX compact systems have a modular design. This allows you to customise the system configuration exactly as you need it for welding your workpiece. The weight, size and design of the workpiece determine which of the compact systems is perfect for your production.



COMPACT SYSTEM CS 1

Premium compact system with two-station positioner with horizontal station change and a clamping surface

>>> 9



COMPACT SYSTEM CS 5

Premium compact system with two-station positioner with horizontal station change, workpiece positioner with turning and swivelling movement

>>> 17



COMPACT SYSTEM CS 2

Premium compact system with two-station positioner with vertical station change, workpiece positioner with vertical rotation and counter bearing

>>> 11



COMPACT SYSTEM CS 6

Premium compact system with two-station positioner with horizontal station change, workpiece positioner with turning and swivelling movement with counter bearing

>>> 19



COMPACT SYSTEM CS 3

Premium compact system with two-station positioner with horizontal station change, workpiece positioner with vertical rotation and counter bearing

>>> 13



COMPACT SYSTEM CS 7

Premium compact system with two-station positioner with horizontal station change, workpiece positioner with turning and tilting movement

>>> 21



COMPACT SYSTEM CS 4

Premium compact system with two-station positioner with horizontal station change, workpiece positioner with vertical rotation and flexible counter bearing

>>> 15

QIROX COMPACT SYSTEM QR-CS-1-U

"Ready to weld" system for welding components up to a weight of 10 kN with a floor-mounted robot

The powerful compact system QR-CS-1 is optimally suited for medium-sized components up to a weight of 10 kN that can be welded without component movement. The compact system QR-CS-1 has a two-station turning table, whereby the station change is carried out by a horizontal rotary movement. The clamping tools for holding the components can be easily mounted on the clamping surface of the positioner.

Features:

- > Horizontal turning table
- > Floor-mounted robot QRC-350
- > For components which can be welded without component movement

Technical data

System floor space	QR-CS-1-U-7.5 kN	QR-CS-1-U-10 kN
Depth	5,800 mm	6,250 mm
Width	4,040 mm	4,940 mm
Height	2,700 mm	2,700 mm
Load per station	7.50 kN	10.00 kN
Max. component length	1,500 mm	2,200 mm
Max. component width	950 mm	1,200 mm
Max. component height	1,000 mm	1,000 mm

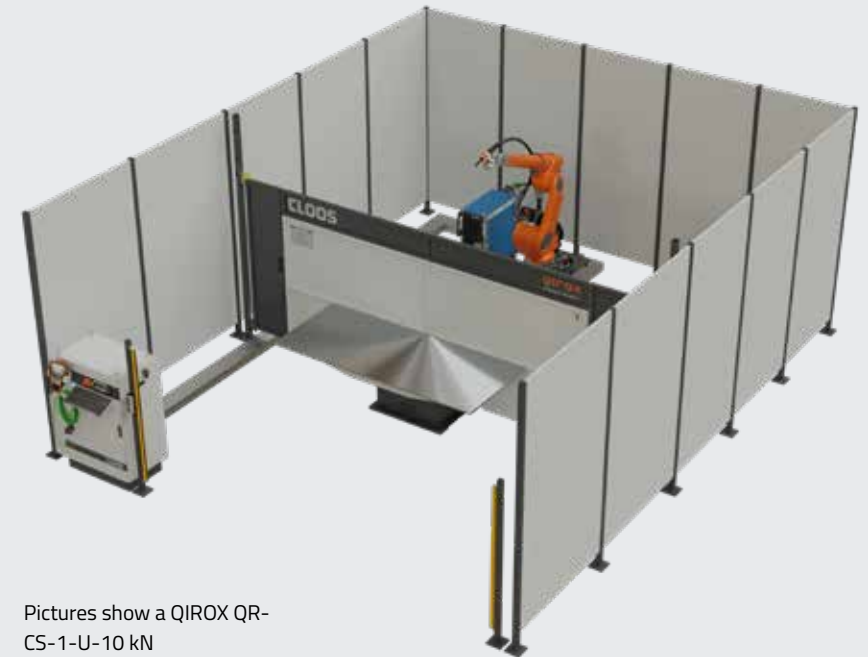

Pictures show a QIROX QR-CS-1-U-10 kN



QIROX COMPACT SYSTEM **QR-CS-1-0**

"Ready to weld" system for welding components up to a weight 10 kN with an overhead-mounted robot

The powerful compact system QR-CS-1 is optimally suited for medium-sized components up to a weight of 10 kN that can be welded without component movement. The compact system QR-CS-1 has a two-station turning table, whereby the station change is carried out by a horizontal rotary movement. The clamping tools for holding the components can be easily mounted on the clamping surface of the positioner.

Features:

- > Horizontal turning table
- > Overhead-mounted robot QRC-350
- > For components which can be welded without component movement

Technical data

System floor space	QR-CS-1-0-7.5 kN	QR-CS-1-0-10 kN
Depth	5,600 mm	6,250 mm
Width	4,040 mm	4,940 mm
Height	3,353 mm	3,353 mm
Load per station	7.50 kN	10.00 kN
Max. component length	1,500 mm	2,200 mm
Max. component width	950 mm	1,200 mm
Max. component height	1,000 mm	1,000 mm



Pictures show a QIROX QR-CS-1-0-10 kN



QIROX COMPACT SYSTEM **QR-CS-2-U**

"Ready to weld" system for welding components up to a weight of 20 kN with a floor-mounted robot

The powerful compact system QR-CS-2 is optimally suited for medium-sized components up to a weight of 20 kN per station that can be welded with a vertical component rotation. The compact system QR-CS-2 has a two-station turning table, whereby the station change is carried out by a vertical rotation. The clamping tools for holding the components can be easily mounted between the faceplates of the positioner.

Features:

- > Vertical station change
- > Workpiece positioner with vertical rotation with counter bearing
- > Floor-mounted robot QRC-350
- > For components which can be welded with a vertical rotation

Technical data

System floor space	QR-CS-2-U-2.5 kN	QR-CS-2-U-5 kN	QR-CS-2-U-10 kN	QR-CS-2-U-20 kN
Depth	5,055 mm	5,515 mm	5,740 mm	6,365 mm
Width	3,248 mm	4,606 mm	6,176 mm	6,668 mm
Height	2,700 mm	2,700 mm	3,000 mm	3,500 mm
Load per station	2.50 kN	5.00 kN	10 kN	20 kN
Max. component length	1,500 mm	2,500 mm	3,500 mm	3,500 mm
Max. component diameter	800 mm	1,000 mm	1,200 mm	1,600 mm



Pictures show a QIROX QR-CS-2-U-10 kN



QIROX COMPACT SYSTEM QR-CS-2-0

"Ready to weld" system for welding components up to a weight 20 kN with an overhead-mounted robot

The powerful compact system QR-CS-2 is optimally suited for medium-sized components up to a weight of 20 kN per station that can be welded with a vertical component rotation. The compact system QR-CS-2 has a two-station turning table, whereby the station change is carried out by a vertical rotation. The clamping tools for holding the components can be easily mounted between the faceplates of the positioner.

Features:

- > Vertical station change
- > Workpiece positioner with vertical rotation with counter bearing
- > Overhead-mounted robot QRC-350-E
- > For components which can be welded with a vertical rotation

Technical data

System floor space	QR-CS-2-0-10 kN	QR-CS-2-0-20 kN
Depth	6,440 mm	7,365 mm
Width	6,176 mm	6,668 mm
Height	4,170 mm	4,170 mm
Load per station	10 kN	20 kN
Max. component length	3,500 mm	3,500 mm
Max. component diameter	1,200 mm	1,600 mm



Pictures show a QIROX QR-CS-2-0-10 kN



QIROX COMPACT SYSTEM **QR-CS-3-U**

"Ready to weld" system for welding components up to a weight of 5 kN with a floor-mounted robot

The powerful compact system QR-CS-3 is optimally suited for medium-sized components up to a weight of 5 kN per station that can be welded with a vertical component rotation. The compact system QR-CS-3 has a two-station turning table, whereby the station change is carried out by a vertical rotation. The clamping tools for holding the components can be easily mounted between the faceplates of the positioner.

Features:

- > Horizontal station change
- > Workpiece positioner with vertical rotation with counter bearing
- > Floor-mounted robot QRC-350
- > For components which can be welded with a vertical rotation

Technical data

System floor space	QR-CS-3-U-5 kN
Depth	6,850 mm
Width	5,540 mm
Height	2,700 mm
Load per station	5.00 kN
Max. component length	2,000 mm
Max. component diameter	1,500 mm



Pictures show a QIROX QR-CS-3-U-5 kN



QIROX COMPACT SYSTEM QR-CS-3-0

"Ready to weld" system for welding components up to a weight 20 kN with an overhead-mounted robot

The powerful compact system QR-CS-3 is optimally suited for medium-sized components up to a weight of 20 kN per station that can be welded with a vertical component rotation. The compact system QR-CS-3 has a two-station turning table, whereby the station change is carried out by a vertical rotation. The clamping tools for holding the components can be easily mounted between the faceplates of the positioner.

Features:

- > Horizontal station change
- > Workpiece positioner with vertical rotation with counter bearing
- > Overhead-mounted robot QRC-350
- > For components which can be welded with a vertical rotation

Technical data

System floor space	QR-CS-3-0-5 kN	QR-CS-3-0-10 kN	QR-CS-3-0-20 kN
Depth	7,250 mm	8,150 mm	8,900 mm
Width	5,740 mm	6,940 mm	7,640 mm
Height	3,370 mm	3,570 mm	3,570 mm
Load per station	5.00 kN	10 kN	20 kN
Max. component length	2,000 mm	3,000 mm	3,500 mm
Max. component diameter	1,500 mm	2,000 mm	2,000 mm



Pictures show a QIROX QR-CS-3-0-20 kN



QIROX COMPACT SYSTEM **QR-CS-4-U**

"Ready to weld" system for welding components up to a weight of 5 kN with a floor-mounted robot

The powerful compact system QR-CS-4 is optimally suited for medium-sized components up to a weight of 5 kN per station that can be welded with a vertical component rotation. The compact system QR-CS-4 has a two-station turning table, whereby the station change is carried out by a horizontal rotary movement. The clamping tools for holding the components can be easily mounted between the faceplates of the positioner.

Features:

- > Horizontal station change
- > Workpiece positioner with vertical rotation and flexible counter bearing
- > Floor-mounted robot QRC-350-E
- > For components in different lengths which can be welded with a vertical rotation

Technical data

System floor space	QR-CS-4-U-5 kN
Depth	6,850 mm
Width	5,340 mm
Height	2,700 mm
Load per station	5.00 kN
Max. component length	2,500 mm
Max. component diameter	1,000 mm



Pictures show a QIROX QR-CS-4-U-5 kN



QIROX COMPACT SYSTEM QR-CS-4-0

"Ready to weld" system for welding components up to a weight 10 kN with an overhead-mounted robot

The powerful compact system QR-CS-4 is optimally suited for small to medium-sized components up to a weight of 10 kN per station that can be welded with a vertical component rotation. The compact system QR-CS-4 has a two-station turning table, whereby the station change is carried out by a horizontal rotary movement. The clamping tools for holding the components can be easily mounted between the faceplates of the positioner.

Features:

- > Horizontal station change
- > Workpiece positioner with vertical rotation and flexible counter bearing
- > Overhead-mounted robot QRC-350-E
- > For components in different lengths which can be welded with a vertical rotation

Technical data

System floor space	QR-CS-4-0-5 kN	QR-CS-4-0-10 kN
Depth	6,850 mm	8,450 mm
Width	5,340 mm	6,940 mm
Height	3,370 mm	3,570 mm
Load per station	5.00 kN	10 kN
Max. component length	2,500 mm	3,000 mm
Max. component diameter	1,000 mm	1,600 mm

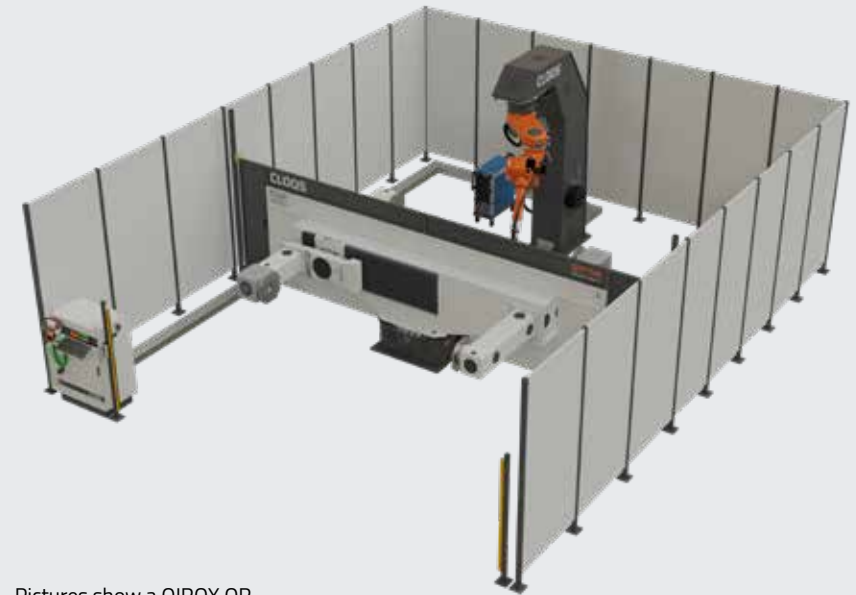

Pictures show a QIROX QR-CS-4-0-10 kN



QIROX COMPACT SYSTEM **QR-CS-5-U**

"Ready to weld" system for welding components up to a weight of 5 kN with a floor-mounted robot

The powerful compact system QR-CS-5 is optimally suited for complex medium-sized components up to a weight of 5 kN per station that can be welded with a turning and swivelling movement of the component. The compact system QR-CS-5 has a two-station turning table, whereby the station change is carried out by a horizontal rotary movement. The clamping tools for holding the components can be easily mounted on the faceplate of the positioner.

Features:

- > Horizontal station change
- > Workpiece positioner with turning and swivelling movement
- > Floor-mounted robot QRC-350
- > For complex components which can be welded with a turning and swivelling movement

Technical data

System floor space	QR-CS-5-U-2.5 kN	QR-CS-5-U-5 kN
Depth	6,150 mm	7,100 mm
Width	4,340 mm	5,440 mm
Height	2,700 mm	2,700 mm
Load per station	2.50 kN	5.00 kN
Max. component length	450 mm	1,300 mm
Max. component diameter	1,000 mm	1,400 mm



Pictures show a QIROX QR-CS-5-U-5 kN



QIROX COMPACT SYSTEM QR-CS-5-0

"Ready to weld" system for welding components up to a weight 20 kN with an overhead-mounted robot

The powerful compact system QR-CS-5 is optimally suited for complex medium-sized components up to a weight of 20 kN per station that can be welded with a turning and swivelling movement of the component. The compact system QR-CS-5 has a two-station turning table, whereby the station change is carried out by a horizontal rotary movement. The clamping tools for holding the components can be easily mounted on the faceplate of the positioner.

Features:

- > Horizontal station change
- > Workpiece positioner with turning and swivelling movement
- > Overhead-mounted robot QRC-350
- > For complex components which can be welded with a turning and swivelling movement

Technical data

System floor space	QR-CS-5-0-5 kN	QR-CS-5-0-10 kN	QR-CS-5-0-20 kN
Depth	7,100 mm	8,450 mm	9,850 mm
Width	5,440 mm	7,140 mm	8,340 mm
Height	3,370 mm	3,570 mm	3,770 mm
Load per station	5.00 kN	10 kN	20 kN
Max. component length	1,300 mm	1,900 mm	2,300 mm
Max. component diameter	1,400 mm	2,000 mm	2,400 mm



Pictures show a QIROX QR-CS-5-0-20 kN



QIROX COMPACT SYSTEM QR-CS-6-U

"Ready to weld" system for welding components up to a weight of 5 kN with a floor-mounted robot

The powerful compact system QR-CS-6 is optimally suited for long medium-sized components up to a weight of 5 kN per station that can be welded with a turning and swivelling movement of the component. The compact system QR-CS-6 has a two-station turning table, whereby the station change is carried out by a horizontal rotary movement. The clamping tools for holding the components can be easily mounted on the faceplate of the positioner.

Features:

- > Horizontal station change
- > Workpiece positioner with turning and swivelling movement with counter bearing
- > Floor-mounted robot QRC-350
- > For complex, long components which can be welded with a turning and swivelling movement

Technical data

System floor space	QR-CS-6-U-5 kN
Depth	6,890 mm
Width	5,140 mm
Height	3,100 mm
Load per station	5.00 kN
Max. component length	1,500 mm
Max. component diameter	1,000 mm

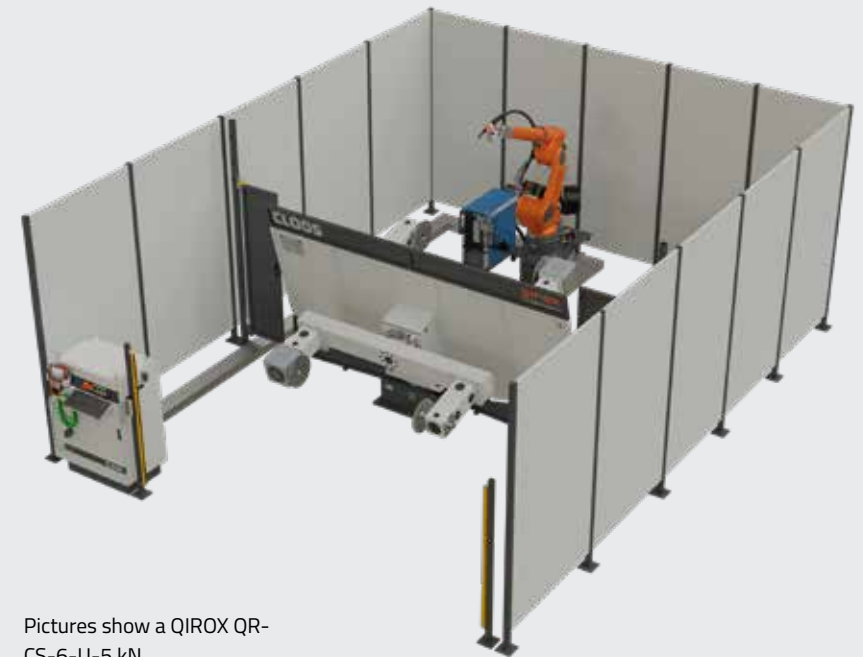

Pictures show a QIROX QR-CS-6-U-5 kN



QIROX COMPACT SYSTEM QR-CS-6-0

"Ready to weld" system for welding components up to a weight 10 kN with an overhead-mounted robot

The powerful compact system QR-CS-6 is optimally suited for long medium-sized components up to a weight of 10 kN per station that can be welded with a turning and swivelling movement of the component. The compact system QR-CS-6 has a two-station turning table, whereby the station change is carried out by a horizontal rotary movement. The clamping tools for holding the components can be easily mounted on the faceplate of the positioner.

Features:

- > Horizontal station change
- > Workpiece positioner with turning and swivelling movement with counter bearing
- > Overhead-mounted robot QRC-350 on a linear lifting chassis
- > For complex, long components which can be welded with a turning and swivelling movement

Technical data

System floor space	QR-CS-6-0-5 kN	QR-CS-6-0-10 kN
Depth	7,384 mm	8,917 mm
Width	5,140 mm	6,940 mm
Height	3,975 mm	4,975 mm
Load per station	5.00 kN	5.00 kN
Max. component length	1,500 mm	2,750 mm
Max. component diameter	1,000 mm	1,500 mm



Pictures show a QIROX QR-CS-6-0-10 kN



QIROX COMPACT SYSTEM QR-CS-7-U

"Ready to weld" system for welding components up to a weight of 10 kN with a floor-mounted robot

The powerful compact system QR-CS-7 is optimally suited for complex medium-sized components up to a weight of 10 kN per station that can be welded with a turning and tilting movement of the component. The compact system QR-CS-7 has a two-station turning table, whereby the station change is carried out by a horizontal rotary movement. The clamping tools for holding the components can be easily mounted on the faceplate of the positioner.

Features:

- > Horizontal station change
- > Workpiece positioner with turning and tilting movement
- > Floor-mounted robot QRC-350-E
- > For complex components which can be welded with a turning and tilting movement

Technical data

System floor space	QR-CS-7-U-10 kN
Depth	6,550 mm
Width	4,540 mm
Height	2,700 mm
Load per station	10 kN
Max. component length	1,400 mm
Max. component diameter	1,400 mm



Pictures show a QIROX QR-CS-7-U-10 kN



QIROX COMPACT SYSTEM QR-CS-7-0

"Ready to weld" system for welding components up to a weight 10 kN with an overhead-mounted robot

The powerful compact system QR-CS-7 is optimally suited for complex medium-sized components up to a weight of 10 kN per station that can be welded with a turning and tilting movement of the component. The compact system QR-CS-7 has a two-station turning table, whereby the station change is carried out by a horizontal rotary movement. The clamping tools for holding the components can be easily mounted on the faceplate of the positioner.

Features:

- > Horizontal station change
- > Workpiece positioner with turning and tilting movement
- > Overhead-mounted robot QRC-350-E
- > For complex components which can be welded with a turning and tilting movement

Technical data

System floor space	QR-CS-7-0-10 kN
Depth	7,250 mm
Width	4,540 mm
Height	3,570 mm
Load per station	10 kN
Max. component length	1,400 mm
Max. component diameter	1,400 mm



Pictures show a QIROX QR-CS-7-0-10 kN



COMPACT SYSTEMS IN COMPARISON

	QR-CS-1				QR-CS-2						QR-CS-3			
	U-7.5kN	O-7.5 kN	U-10kN	O-10 kN	U-2.5kN	U-5kN	U-10kN	O-10 kN	U-20kN	O-20 kN	U-5kN	O-5 kN	O-10 kN	O-20 kN
Max. component length [mm]	1500	1500	2200	2200	1400	2400	3400	3400	3400	3400	1900	2400	2900	3400
Max. component width [mm]	950	950	1200	1200	750	950	1100	1100	1500	1500	1400	1400	1900	1900
Max. component height [mm]	1000	1000	1000	1000	750	950	1100	1100	1500	1500	1400	1400	1900	1900
Max. component weight [kN]	7.5	7.5	10	10	2.5	5	10	10	20	20	5	5	10	20

	QR-CS-4			QR-CS-5					QR-CS-6			QR-CS-7	
	U-5kN	O-5 kN	O-10 kN	U-2.5kN	U-5kN	O-5 kN	O-10 kN	O-20 kN	U-5kN	O-5 kN	O-10 kN	U-10kN	O-10 kN
Max. component length [mm]	2400	2400	2900	650	750	750	1450	1700	1500	1400	2500	1000	1000
Max. component width [mm]	900	900	1500	450	1300	1300	1900	2300	950	950	1400	1400	1400
Max. component height [mm]	900	900	1500	450	1300	1300	1900	2300	950	950	1400	1400	1400
Max. component weight [kN]	5	5	10	2.5	5	5	10	20	5	5	10	10	10

BASIC EQUIPMENT:

The QIROX compact systems provide you with premium class "ready to weld" robotic welding systems. Depending on your welding task, component size and component weight, you decide on one of the versions. This includes a double-station workpiece positioner for holding the clamping tools for the components, complete MIG/MAG welding equipment with many welding processes, a robot for guiding the welding torch and a complete safety equipment. All components are optimally matched to each other and ensure trouble-free and efficient automated welding.

On the following pages you will find the most important components of the QIROX compact systems from CLOOS.

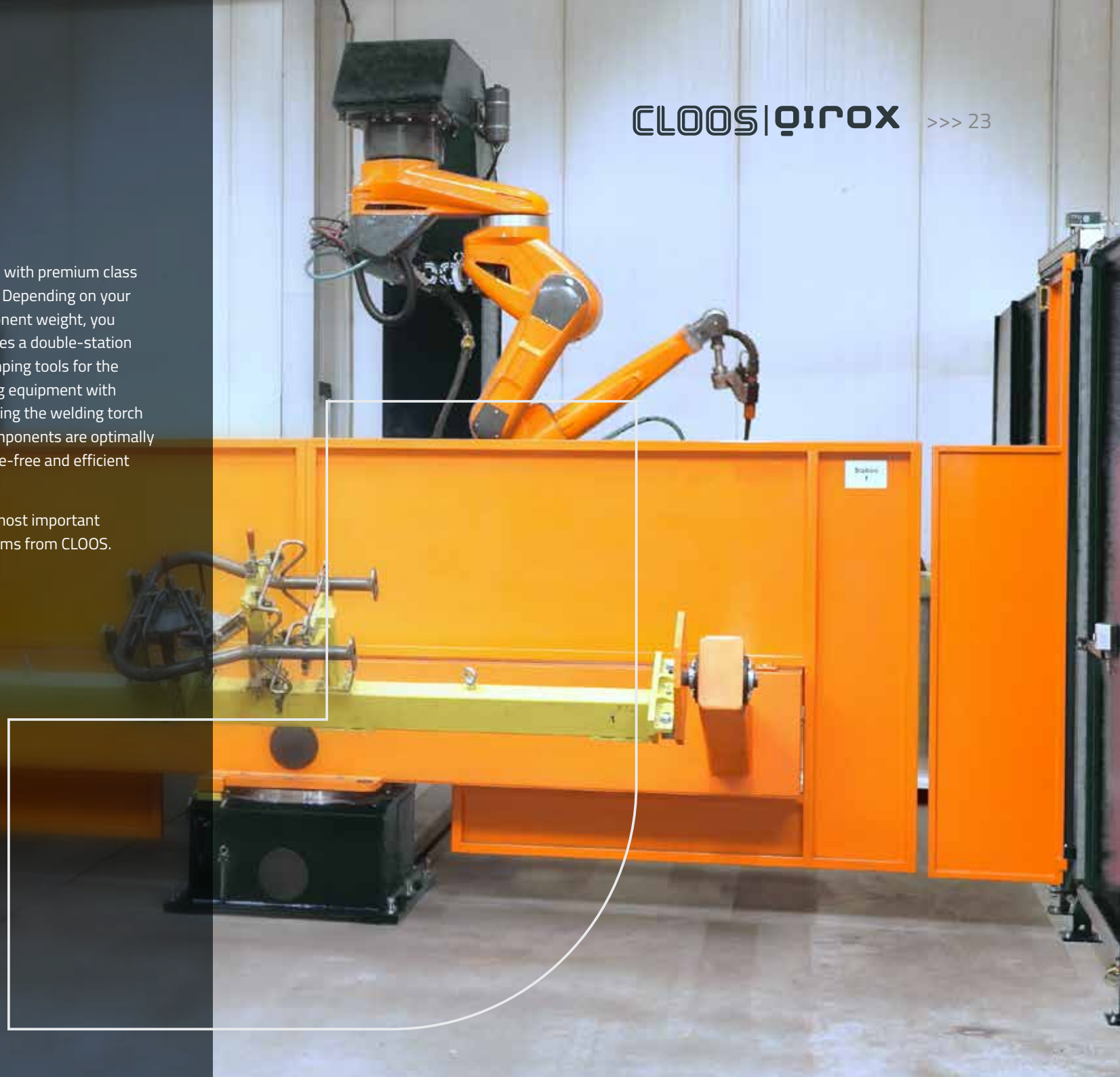

BASIC EQUIPMENT OF A COMPACT SYSTEMS

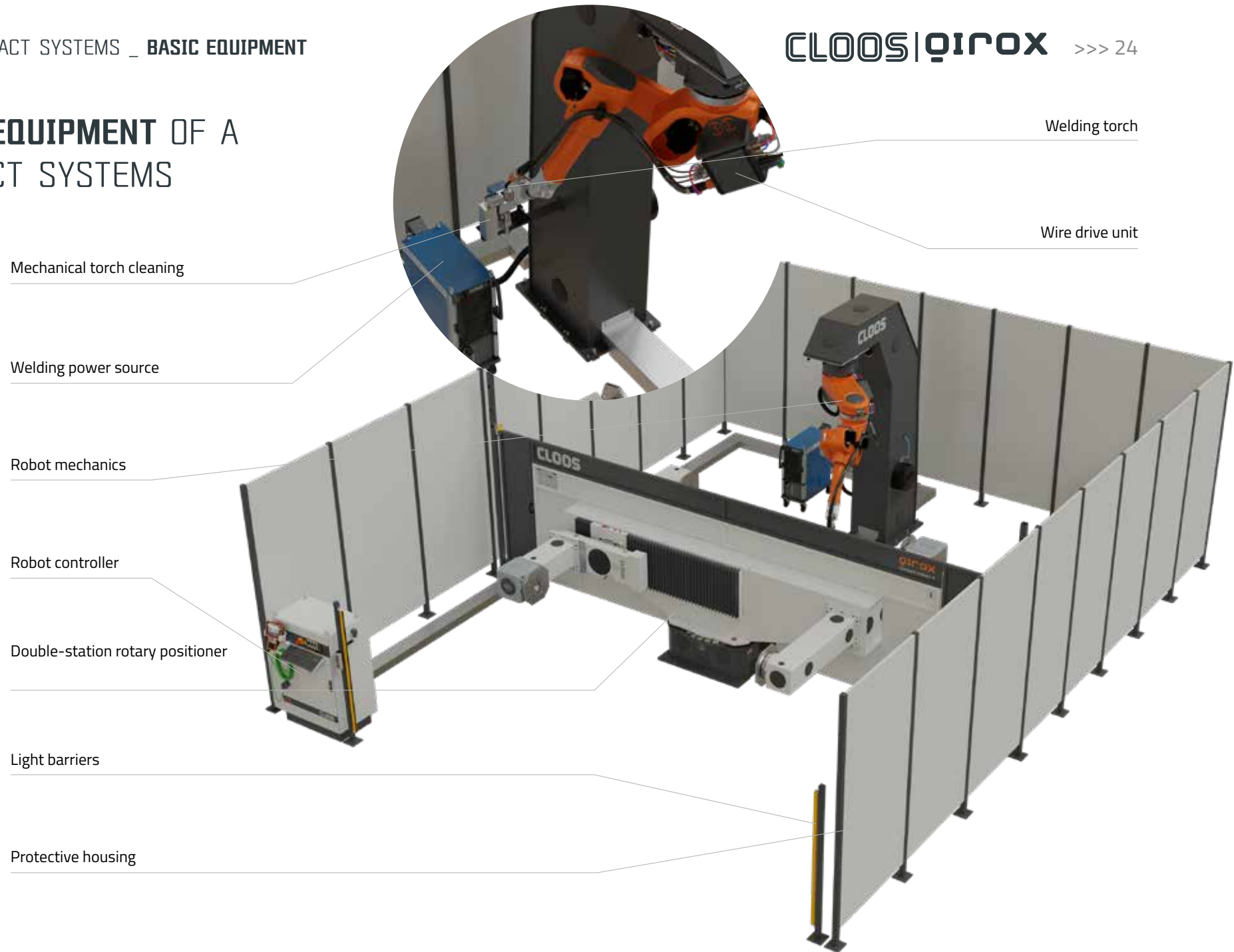

QIROX ROBOT MECHANICS WL SERIES

Enhancement of the application range due to a tool changing system

MIG/MAG



TIG



DuoDrive

Standard

Single wire



Tandem

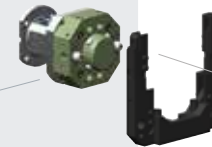

Sensors



CONTROL CENTRE OF THE QIROX ROBOT SYSTEMS

- > High end distributed computing power: Dynamic movement and a high path accuracy of the robot
- > Absolute reliability: Clear dirt-protected arrangement and easy change of all components in the robust system cabinet
- > Numerous extra functions: Many optional combinations with the RoboPlan offline programming software and CarolaEdi, Remote Service Manager (RSM), Process Data Manager (PDM) and User Management (UMS) by CLOOS



OPTIMUM MAN-MA- CHINE INTERFACE

- > Intuitive programming:
Quick and easy for reduced programming times
- > Efficient interfaces:
Integration of all process-managing devices and sensors into the programming of the QOS
- > C-Gate:
Built-in future for the world of Industry 4.0



QIROX WORKPIECE POSITIONERS

The two-station workpiece positioners of the compact systems are designed for parallel work of the system operator and the robot.

The station change is made by a vertical or a horizontal rotation as soon as the loading and unloading operations

have been completed and the robot has finished processing the workpiece. The two-station positioners are designed for small to medium-sized, light to medium-weight workpieces and ensure a high throughput of the robot system.

Mature combination of different movement devices

- > Welding of complex contours without interruption
- > Improved accessibility of all weld seams on the workpiece
- > Very high system availability with long operating life
- > Exact path accuracy and high repeatability





QINEO **NexT PREMIUM**

for automated welding

The QINEO NexT Premium has all important components and functions "on board" so that you are perfectly prepared for the future. The heart of the QINEO NexT is an inverter power unit developed by CLOOS which clocks with a high frequency. This allows an even better arc control for excellent results: The unique welding characteristics enable you to solve complex welding tasks perfectly.

A multitude of optional components and functions make the QINEO NexT to be your individual power source – exactly how you need it for your tasks of automated welding.

- > High-quality inverter technology for excellent weld quality
- > Robust housing and good user-friendly operation guarantee a high availability
- > Prepared for all commonly used standard interfaces
- > Optimal integration of all functions of QIROX controller and QINEO NexT into one unit, made possible by the bidirectional interface QTI
- > The Premium operating module is designed for the highest level of welding
- > A wide range of accessories guarantees that the NexT can be adapted to your needs

WIRE FEED DISTANCE

Safe wire feed for perfect welding results:

- > Powerful 4-roller drive
- > Slip- and abrasion-free wire feed
- > Maintenance-friendly

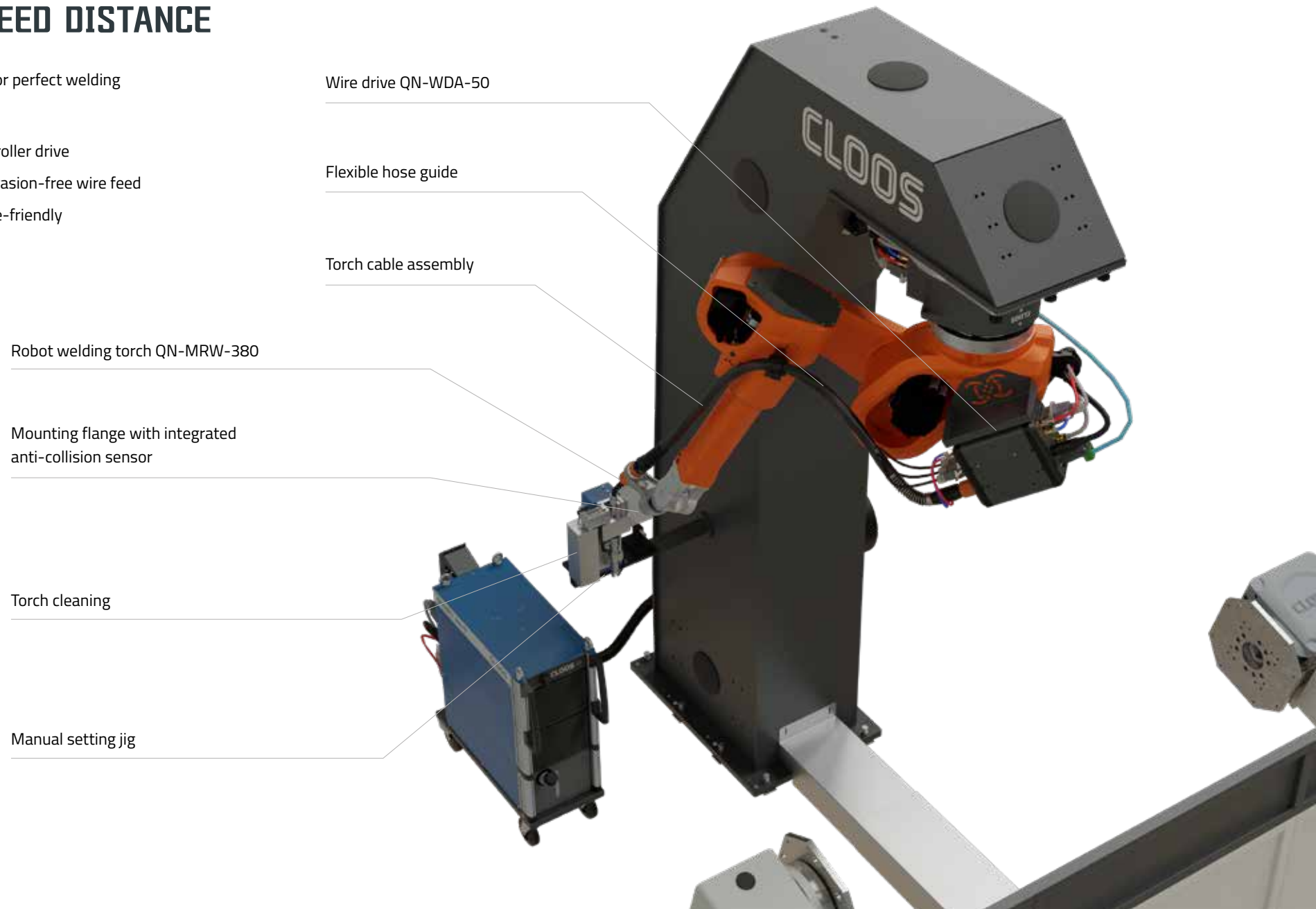

Wire drive QN-WDA-50

Flexible hose guide

Torch cable assembly

Robot welding torch QN-MRW-380

Mounting flange with integrated anti-collision sensor

Torch cleaning

Manual setting jig

SAFETY TECHNOLOGY

The standard safety devices ensure a safe handling of the compact systems:

- > DIN EN ISO 13850:
- > DIN EN ISO 10218-1
- > EC Machinery Directive 2006/42/EG
- > DIN EN ISO 10218-2

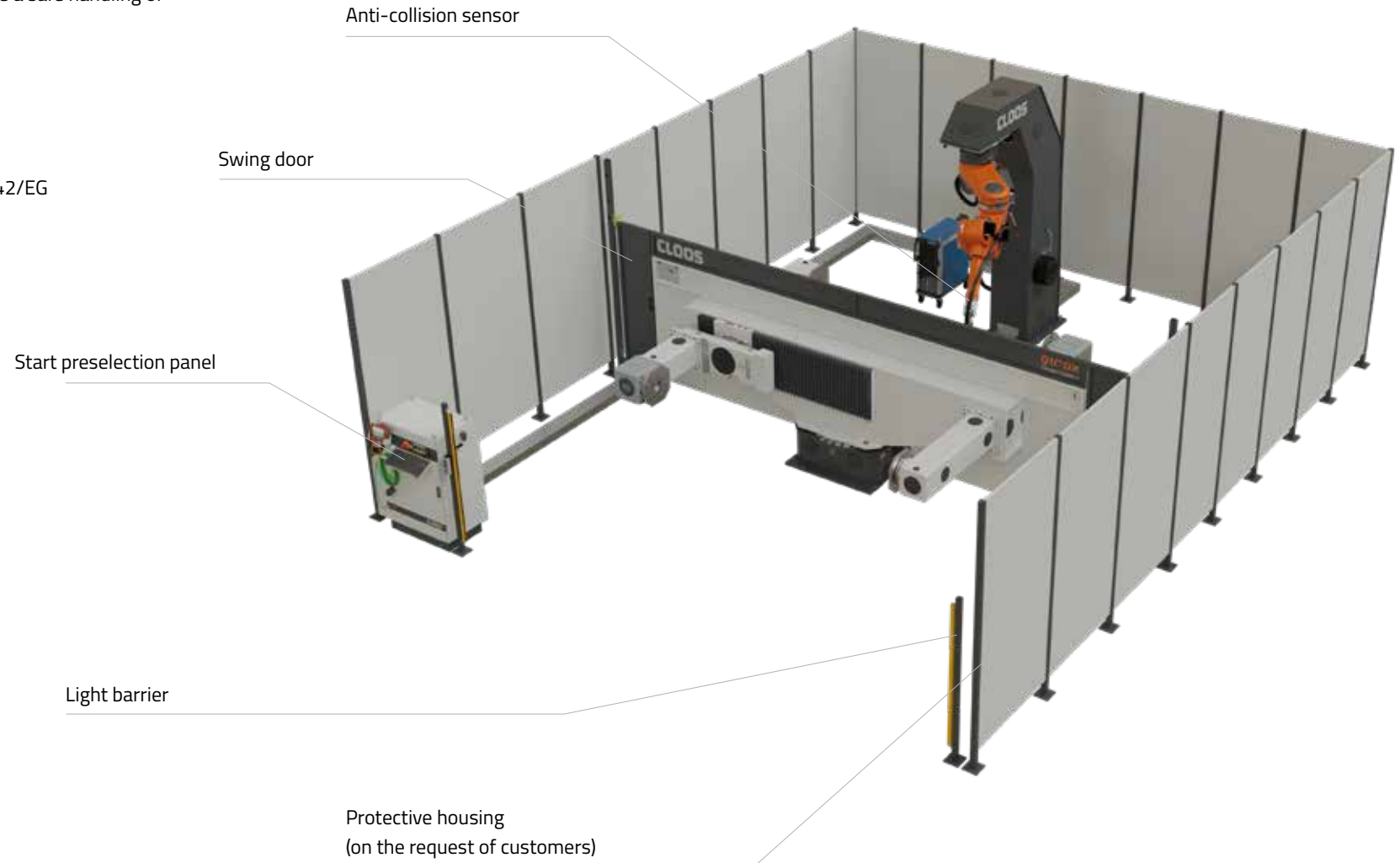

OPTIONS

CLOOS offers a comprehensive package of customised options to further increase the efficiency and range of applications of the QIROX compact system. For example, you can benefit from the robot mechanics with hollow shaft wrist when the component is tight. In addition, our modular system with sensors for a wide range of requirements ensures weld seam quality when component tolerances occur. You can also use a wide range of other add-ons that the QIROX compact system fulfils to meet all your production requirements.

The offline programming system QIROX RoboPlan offers an increase in the utilisation of the QIROX compact system. Production is not interrupted for the programming of new components and production planning is simply carried out on a PC on which QIROX RoboPlan is installed. Other QIROX robot systems can be easily integrated into the offline programming system.

With the C-Gate from CLOOS, you can make the QIROX compact system fit for Industry 4.0. Track production parameters in real time, record and archive all machining parameters in relation to the component. Many other tools support your maintenance staff in keeping the compact system running successfully.

Please contact us for further options and additions.

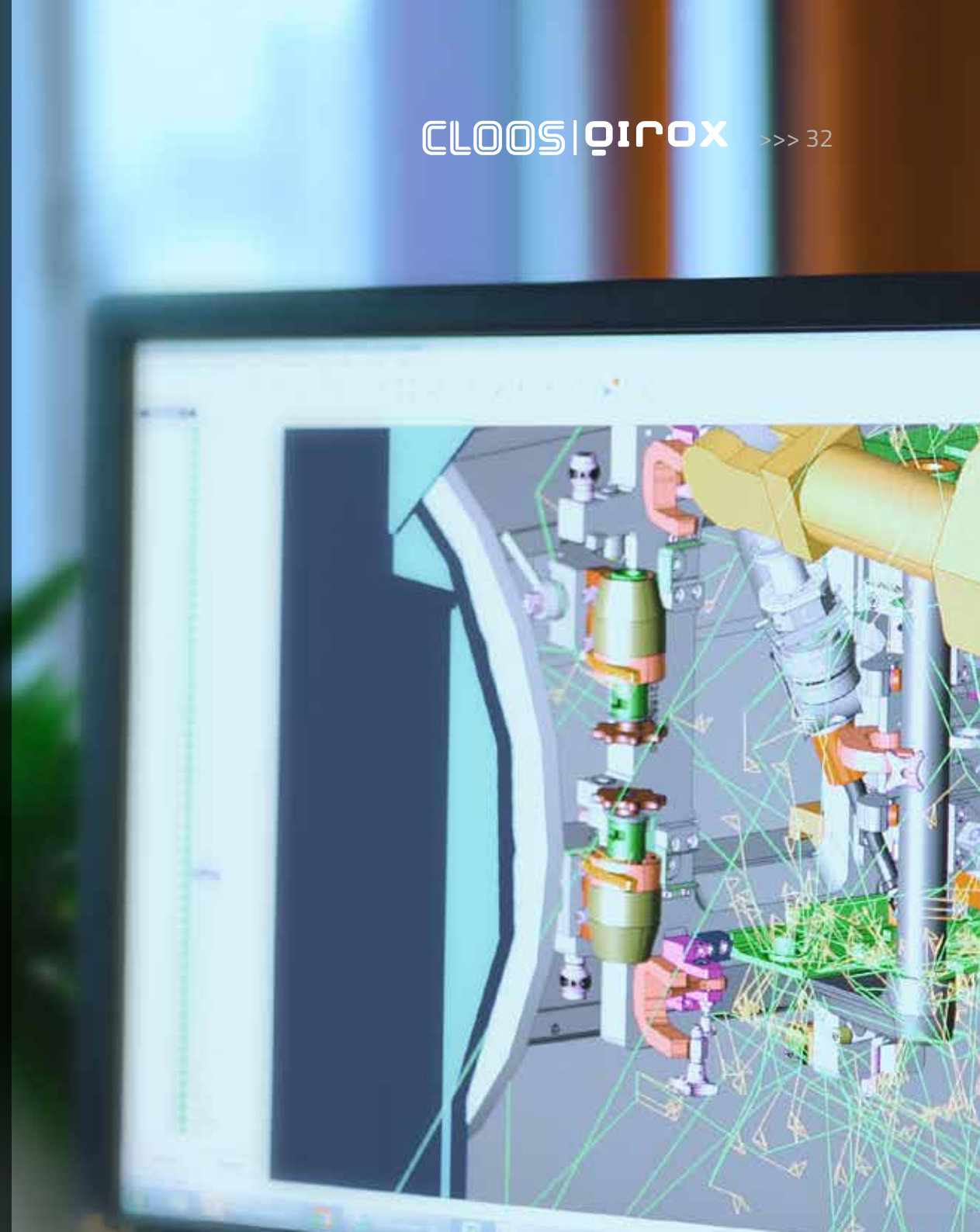

QIROX ROBOT MECHANICS OF THE WL SERIES WITH HOLLOW SHAFT WRIST

MIG/MAG

DuoDrive

Standard



Sensors



SENSITIVITY FOR **OPTIMUM WELDING PROCESSES**

The main task of our sensor systems is to ensure quality control through precise welding procedures. The flexibility of your systems increases due to the control and compensation of tolerances between the programmed paths and the real workpieces.

For a wide range of materials and applications, you can choose from four field-proven CLOOS sensors which further perfect automated welding by intelligent control and guidance. The optimised workflow minimises rework. This allows you to work even more economically and produce high-quality products.

- > Advantages for increased productivity
- > Four proven sensors for the most different materials, weld shapes and applications
- > Perfectly tailored to the QIROX system solution
- > Considerably improved weld quality
- > Reduction of manual effort – minimum rework
- > Opening up new application possibilities with CLOOS sensor systems

TACTILE GAS NOZZLE SENSOR

The tactile wire sensor uses electromechanical sensing technology to determine the start and end of the weld seam – deviations due to workpiece tolerances are corrected.



ARC SENSOR

During the welding, the CLOOS arc sensor measures whether the burner position actually agrees with the programmed track. In the case of deviations, for example by heat distortion, the robot recognises the real contour, tolerances are directly compensated.

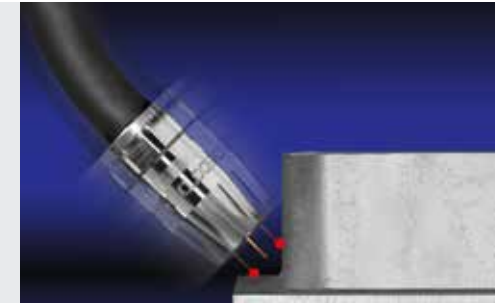

LASER OFFLINE SENSOR

Before start of the welding process, the system scans the beginning and/or the end of the weld offline and records the measurement data. This data is used to adapt the programming to the measured actual state.



LASER ONLINE SENSOR

This high-tech sensor offers maximum flexibility. The tracking section is measured online during welding – the workpiece position of, for example, the welding torch or the laser beam and various process parameters are adjusted continuously to reach an optimum welding result.



OFFLINE PROGRAMMING WITH **RoboPlan**

Programming of welding and travel paths as well as sensor routines on 3D models

While the robot system is in production, a new program can be simultaneously produced in RoboPlan. RoboPlan allows the generation of welding and travel paths as well as sensor routines on 3D models and the welding parameters and other functions required for running the program can then be defined. The program developed in this way is transferred into the robot controller directly. This process is less time-consuming than the generation of a new program in the robot system using the TEACH process. Thus you increase the system utilisation, optimise the production process and make your welding production more flexible.

Your benefits:

- > Offline programming during production: Increase of the degree of system utilisation
- > Quick product and component adaptation: Optimisation of the production process
- > Prototype programming: Improved production planning
- > More parts within a shorter time: Higher flexibility

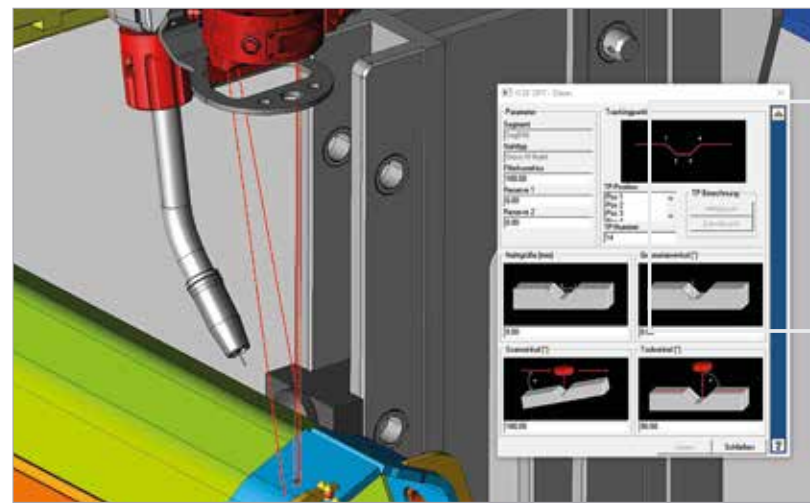

C-GATE: INDUSTRY 4.0 ENABLED

The digitisation platform for your company: Access information from your welding production in real-time.

All information is entered and processed centrally in an integrated information and communication tool. This allows you to monitor and control your production processes down to the smallest detail.



PRODUCTION MODULE

The production module enables a comprehensive online monitoring of your welding machines and robot systems.

Your benefits:

- > Transparent, digitised production process
- > Optimised production processes
- > Reduction of set-up and downtimes
- > Support on the way to the Smart Factory



QUALITY MANAGEMENT MODULE

The quality management module focuses on the individual component with its production and welding process data.

Your benefits:

- > Immediate reaction to deviations in the production process
- > Detailed component overviews, protocols and reports
- > Production and station tracking
- > Fulfilment of the technical welding quality requirements



MAINTENANCE MODULE

The maintenance module allows the external access to production systems and welding machines for information, maintenance and repair purposes.

Your benefits:

- > Remote maintenance
- > Reminder of maintenance plans
- > System diagnostics
- > Updates for controller
- > Predictive Maintenance



REFERENCES

To give you a brief impression of the wide range of applications for QIROX compact systems, the following pages show you a selection of systems used by customers. Further information is available on our website.

We are always happy to talk to you!



ROBOT SYSTEM FOR WELDING HIGH-QUALITY STAINLESS STEEL PUMPS

Hilge GmbH & Co. KG

- > Component: Steel pump impeller
- > Industry: Container construction
- > Welding process: TIG DC



On an enclosed surface of 5600 x 4400 mm a double station workpiece positioner for a horizontal rotation is placed in the middle. While the robot welds in one station, the operator removes the welded workpiece from the second station and loads it again. Both stations have a swivelling and turning axis to perfectly place the pump components external housing, impellers and suction connections for the QIROX 350-E robot.



QIROX ROBOT ENSURES **OPTIMUM WELD QUALITY** AT ORION BAUSYSTEME

Orion Bausysteme

- > Component: Bicycle parking system
- > Industry: Construction suppliers
- > Welding process: Speed Weld



Due to the use of a compact welding robot system, Orion achieves optimum welding results at a reduced production time when welding bicycle parking systems and canopies. The centrepiece of the new system is the QIROX QRC-410-E welding robot. The seventh axis considerably extends the robot's working range and enables the welding torch to be optimally positioned.

The 2-station workpiece positioner WP-DH-TC-5 kN with horizontal change and vertical rotation with counter bearing consists of two opposition stations. The two-station design allows the components to be inserted in one station while the robot welds in the other. By using the automated welding technology, the company achieves precisely reproducible welding results and an excellent product quality.





COMPACT ROBOT SYSTEM FOR MAXIMUM FLEXIBILITY AT HENKE

Henke GmbH



- > Component: Traverses for pack racks
- > Industry: Automotive
- > Welding process: Vari Weld

Henke GmbH has relied on the welding technologies by CLOOS for more than 30 years. In 2018, the specialists for industrial sheet metal processing and transformer accessories commissioned a new compact CLOOS robot system.

The equipment of the new robot system and the process variety enable maximum production flexibility. Whether long narrow or cubic components, aluminium or steel – Henke can flexibly respond to individual customer requirements. Henke currently manufactures, among other things, aluminium roof racks, light box covers and electrical switch boxes with the new robot system.



QIROX ROBOT WELDS **COMPACT CARGO BIKES**

multi-cycles GmbH

- > Component: Components for cargo bikes
- > Industry: Automotive
- > Welding process: MoTion Weld



For welding cargo bikes, multi-cycles GmbH in Cologne relies on an automated solution by CLOOS. Thanks to the flexible design of the system and the use of different welding processes such as MoTion Weld and Vari Weld, the robot can weld different steel and aluminium components with consistently high quality. The robot system consists of two opposite welding stations, each of which has a horizontal swivelling axis with an L-shaped extension arm. The counter bearing stabilises even long workpieces during welding. The station change is made by a horizontal rotation.

Because of the two-station arrangement, the machines can be loaded mutually. The centrepiece of the system is the QIROX robot QRC-350-E. The six-axis articulated arm robot has an excenter axis 7 which is integrated between robot base and centre point of axis 1. The seventh axis extends the working range for optimal positioning of the welding torch.



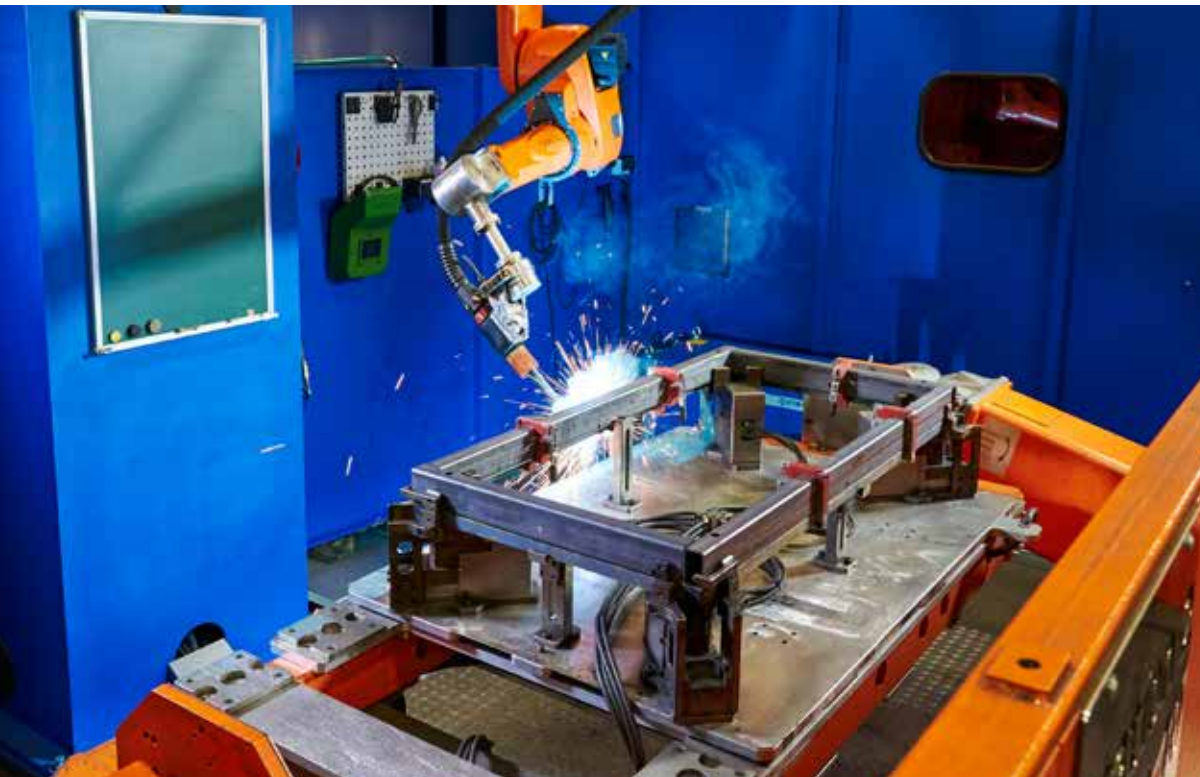

INDIVIDUAL ROBOT SYSTEM ENABLES **FLEXIBLE PRODUCTION** AT LANGMATZ

Langmatz GmbH

- > Component: Manhole cover
- > Industry: Electrical industry
- > Welding process: Vari Weld



Langmatz GmbH develops and sales technical solutions made of plastics and metal for the power supply, telecommunications and traffic engineering industries.

For welding their manhole systems, they use a QIROX QR-CS-30 compact system, which is designed for workpieces weighing up to 500 kg. The system comprises a two-station rotary indexing table with a turning axis and counter bearing for each station, enables simultaneous welding and loading/unloading and has a common frame for the robot and positioner which ensures fast assembly. The C-shaped frame with an overhead-mounted QIROX QRC-350 robot and a rotating extension arm allows large parts to be welded and stations to be changed. A third station was added at the customer's request.





PERFECTLY TAILORED

So that your production runs at full speed.



1 | ANALYSIS

We analyse your requirements and determine all production-relevant variables - for your optimum solution



2 | ADVICE

We provide you with consistently performance-orientated advice and develop possible solutions for your requirements.



3 | SYSTEM CONCEPT

We define a system concept that integrates seamlessly into your overall production - always focussing on maximum efficiency.



4 | CONSTRUCTION

We utilise the strengths of our modular product series to your advantage. This is how we keep investment costs low!



5 | PRODUCTION

From the smallest individual part to complex complete systems, we deliver 100% quality - including function test before delivery.



6 | COMMISSIONING

We integrate your new system seamlessly into your overall production.



7 | TRAINING

In our training centre, we provide your team with practical content on programming, handling and maintenance.



8 | SERVICE

With a strong network of representations, service centres and our high-performance production facilities, we are always just a phone call away.



9 | SUPPORT

We advise you on all expansions, modifications and overhauls of your systems.



CLOOS WORLDWIDE

>>> 45

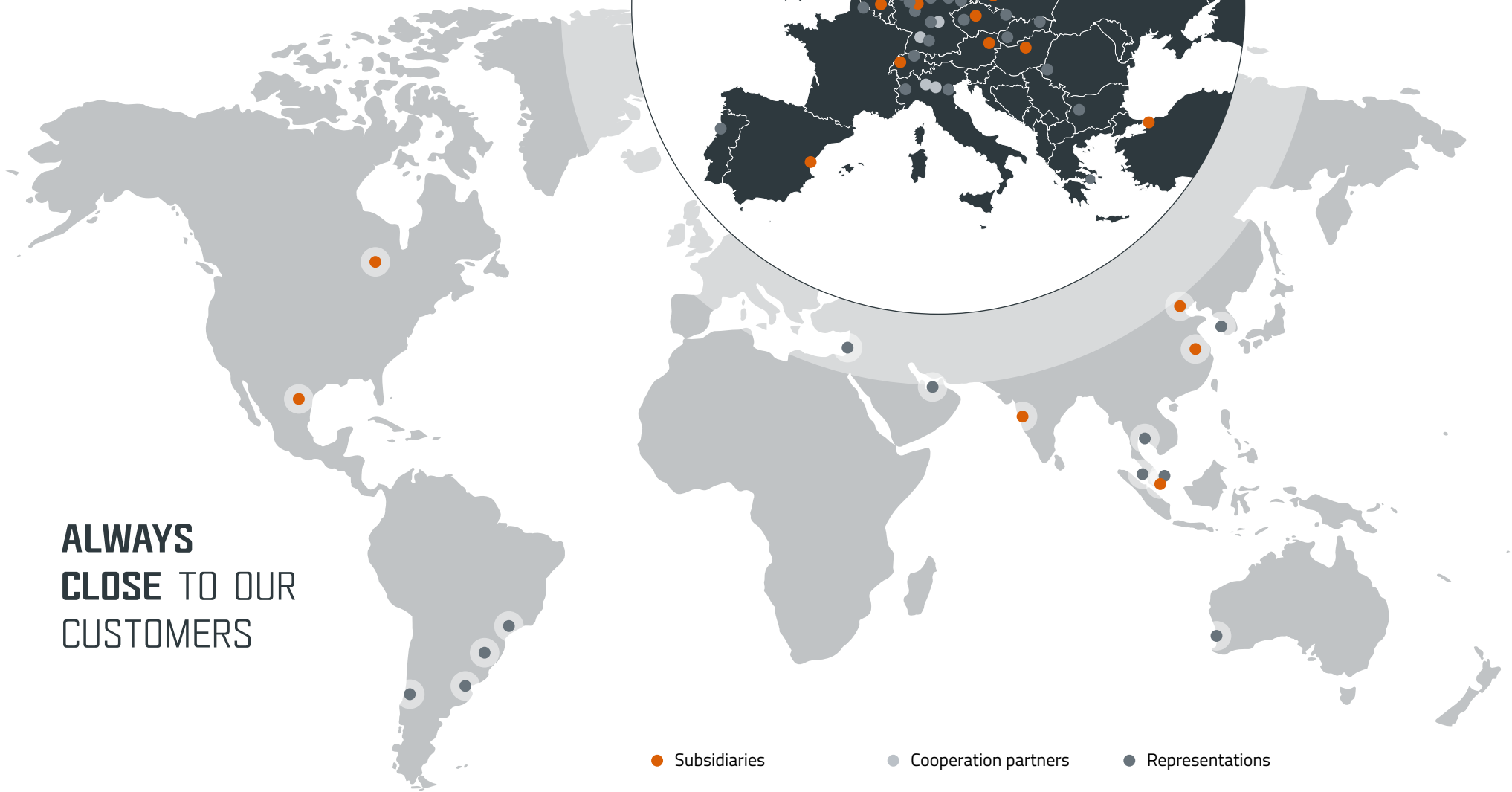

**ALWAYS
CLOSE TO OUR
CUSTOMERS**

- Subsidiaries
- Cooperation partners
- Representations



CLOOS

CARL CLOOS SCHWEISSTECHNIK GMBH

Main office: Carl-Cloos-Strasse 1
Central warehouse: Carl-Cloos-Strasse 6
35708 Haiger
Germany

Telefon +49 (0) 2773 85-0
E-Mail info@cloos.de
www.cloos.de



CONNECT WITH US!



CONNECT WITH US!