

ROLLER GEAR INDEX DRIVE

Product Overview

You are currently viewing:



**RGS/RGD Shaft/
Flange Drives**



**Parallel Shaft/
Flange Drives IN-PAR**

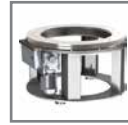

**RNG Easy Access
Dial Indexers IN-RNG**

Additional Indexing Products:



**Servo Positioner
Rotary Table IN-GTB**



Rite-Link Conveyors IN-RLC



RDM Dial Indexers IN-RDM



**Table-Top Modular
Conveyors IN-TTC**



RA Right Angle Drives IN-RA



**Heavy Duty
Modular Conveyors IN-HDC**



RD HD Dial Indexers IN-RD



LPP Linear Part Handles IN-LPP



E-Series HD Drives IN-EHD



RPP Rotating Part Handlers .. IN-RPP



MDE/HDE Indexers IN-MDE



Overload Clutches IN-CLU



RSD Flexible Servo Drives .. IN-RSD



Custom Cams IN-CAM

ROLLER GEAR INDEX DRIVE

Precision Indexing | Table of Contents



Features:

The **CAMCO Roller Gear Index Drives** are robust, versatile units suitable for a wide variety of applications.

Available with a flange (RGD) or shaft (RGS) output

All six surfaces are machined for universal mounting

Optional center thru-hole in flange version facilitates passage of electrical wiring, pneumatic lines or mechanical linkages

Short camshaft motion periods, due to oversized cam design, are well suited for continuous running applications or for special motion requirements such as oscillating motions

Table of Contents

How to Order	3
40RGD/40RGS	5
50RGD/50RGS	7
70RGD/70RGS	9
80RGD/80RGS	11
110RGD/110RGS	13
350RGD/350RGS	15
500RGD/500RGS	17
600RGD/600RGS	19

RGD/RGS SERIES

Roller Gear Index Drive | How To Order

Indexer Ordering Procedure

1. Model
 2. Input Shaft Configuration
 - Side 1
 - Side 2
 - Double Input – DI (Standard)
 3. Cam Lead (Helix)
 - Right Hand (Standard)
 - Left Hand
- NOTE: Input may rotate in either direction to achieve desired direction of output rotation.
4. Indexer Mounting Position: 1-6
 5. Indexer Housing Mounting Holes: Side 1-6 (more than one side can be selected)

Reducer Ordering Procedure

1. Model
2. Ratio
 - 10:1, 15:1, 20:1, 25:1, 30:1, 40:1, 50:1, 60:1
3. Motor Adapter
4. Reducer Input Shaft Extension
 - Single Input (SE) or Double Input (DE)
5. Mounting
 - Mounting Position A, B, C, or D
 - Mounted on Indexer Side 1 or Side 2
6. Input Shaft Orientation
 - Left or Right (See Diagram Below)

Input Shaft Configuration (Top View)

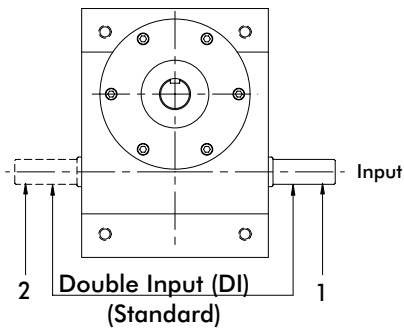

Input Shaft Rotation

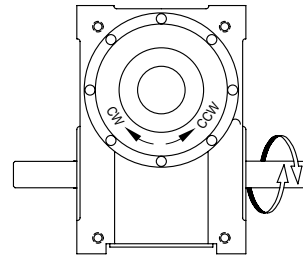

Relative Rotation for Right Hand Cam:

CW Input Side 1 CCW Output
CCW Input Side 2 CCW Output

NOTE: Input can be driven in either direction

Indexer Housing Mounting Holes

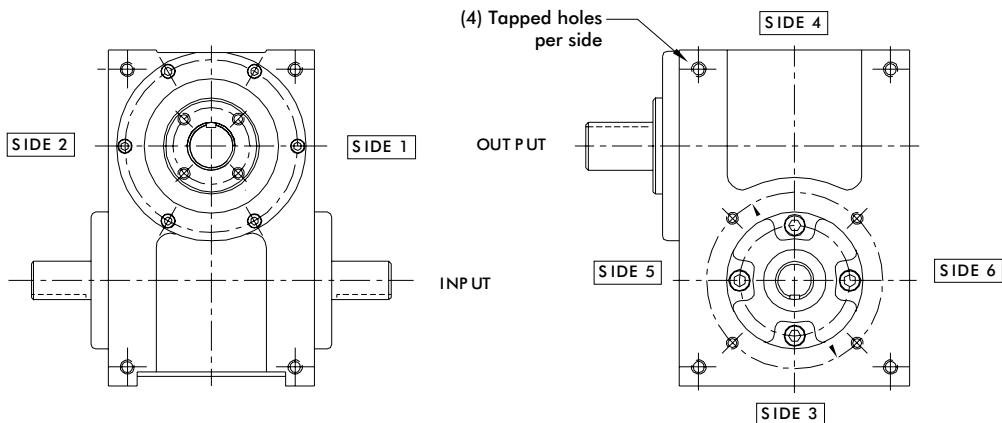

RGD/RGS SERIES

Roller Gear Index Drive | Indexer Mounting Position

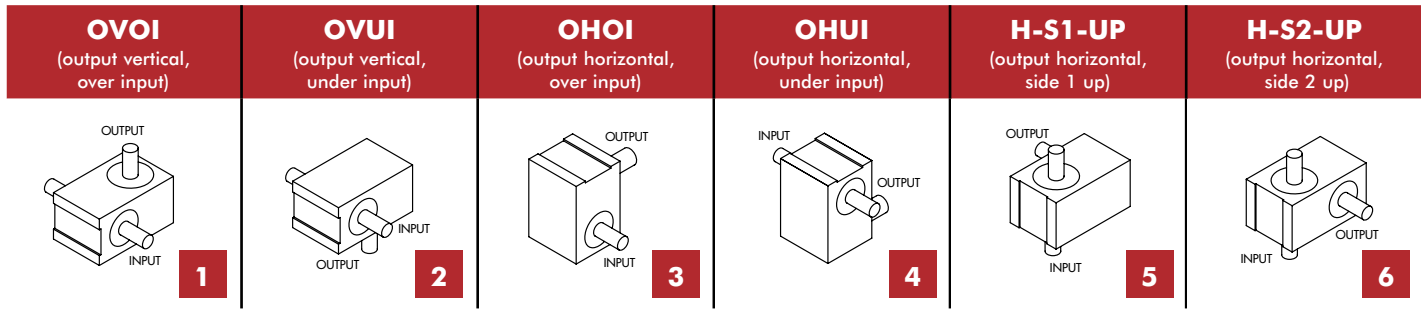

Gear Reducer Mounting Positions (Figure 4)

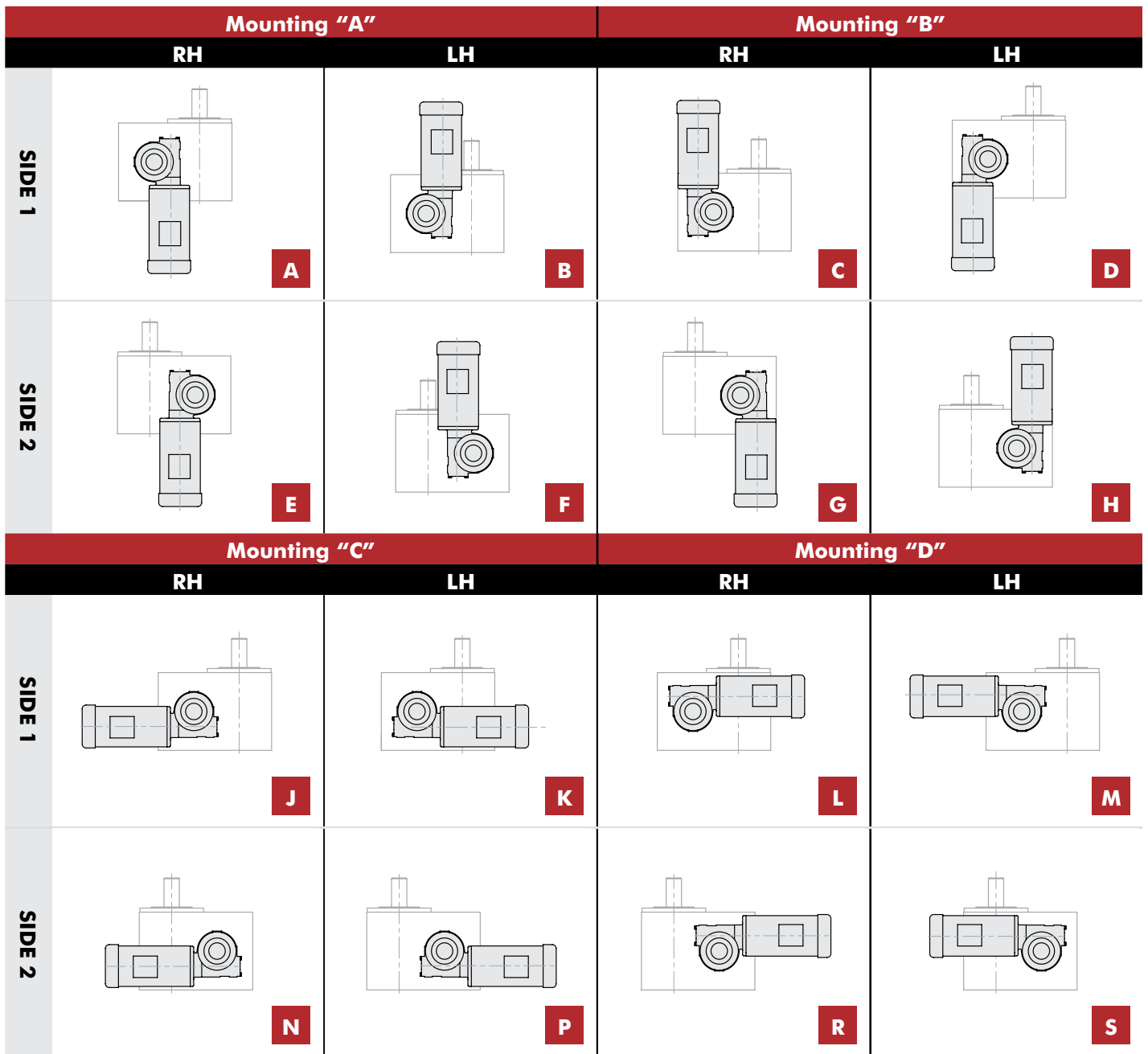

40RGD/40RGS SERIES

Roller Gear Index Drive | Dimensions

40RGD

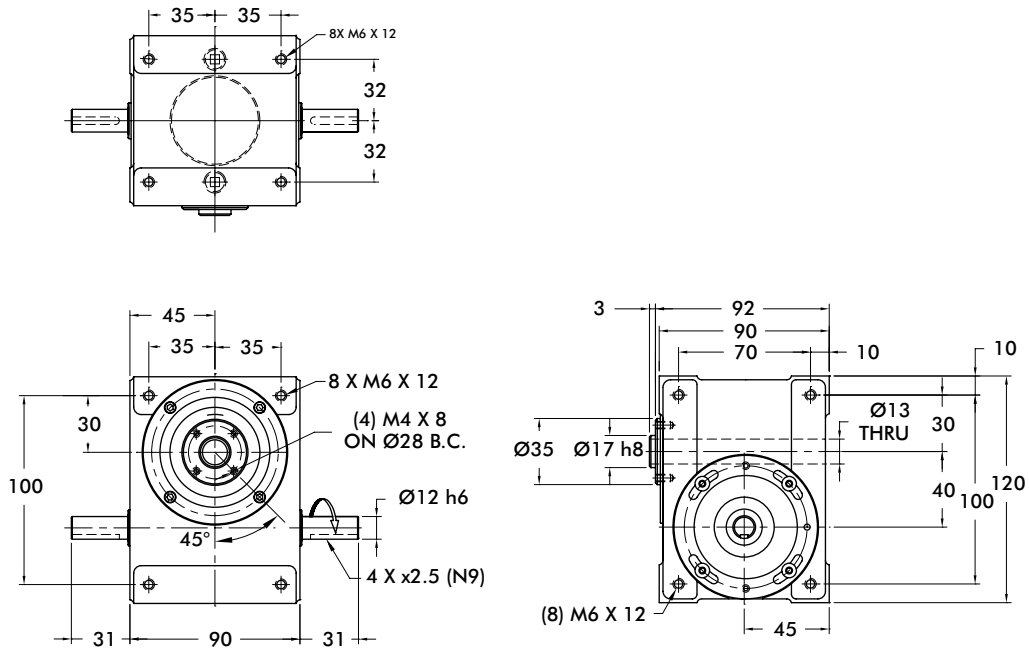

40RGS

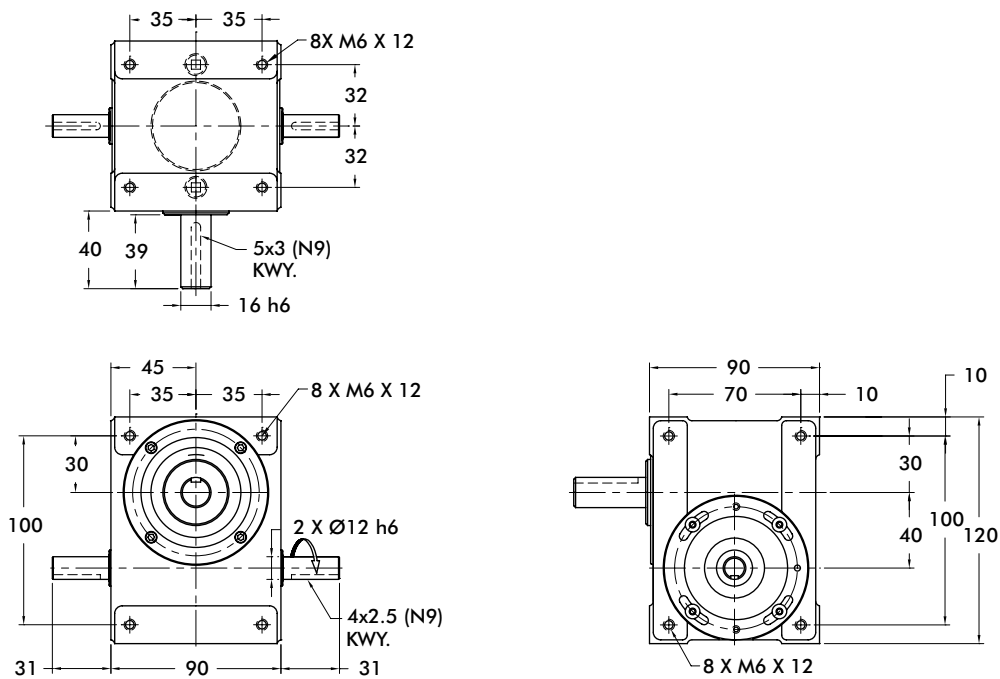

Unless otherwise noted,
all dimensions are in mm.

40RGD/40RGS SERIES

Roller Gear Index Drive | Features | Optional Accessories | Technical Information

40RGD/40RGS Indexer Capacities						
Stops	Index Period	Motion	B ₁₀ Capacity at 50 RPM (in-lb)	RGD Internal Inertia (lb-in ²)	RGS Internal Inertia (lb-in ²)	Model
2	270	ms	150	0.3	0.4	40RG(D/S)2H12-270
3	270	ms	187	0.3	0.4	40RG(D/S)3H12-270
4	270	ms	214	0.4	0.4	40RG(D/S)4H12-270
	180	ms	225	0.4	0.4	40RG(D/S)4H12-180
6	270	ms	193	0.3	0.4	40RG(D/S)6H12-270
	90	ms	216	0.3	0.4	40RG(D/S)6H12-90
8	270	ms	216	0.4	0.4	40RG(D/S)8H12-270
	90	ms	249	0.4	0.4	40RG(D/S)8H12-90
12	270	ms	124	0.3	0.4	40RG(D/S)12H9-270
	90	ms	139	0.3	0.4	40RG(D/S)12H9-90
16	270	ms	254	0.4	0.4	40RG(D/S)16H12-270 II
	120	ms	312	0.4	0.4	40RG(D/S)16H12-120 II
24	180	ms	173	0.3	0.4	40RG(D/S)24H9-180 II
	120	ms	326	0.3	0.4	40RG(D/S)24H12-120 III

Other Motions (stops and index periods) available. Contact your DESTACO sales representative for more information.

Features

- Fully Metric
- Universal Mounting: mounting holes on any of 6 sides
- Center Through Hole (.50 in./13 mm Diameter) in RGD model.
- Right Hand Cam

Output Load Capacity (loads carried during index):

	RGD	RGS
Radial	1,107 lbs	206 lbs
Thrust/Axial	791 lbs	492 lbs
Moment	762 in-lb	405 in-lb

Accuracy ±90 arcsec / ±.0013" at 3" Radius

Repeatability ±22 arcsec / ±.0003" at 3" Radius

Optional Accessories

- STM RMI28 Gear Reducer (ratios from 7:1 to 100:1) with
 - IEC56B14 Motor Adapter
 - 1/12 hp AC Motor and Inverter Drive (up to 60 cpm)
- Single or Dual Cycle Cam and Limit Switch
- Left Hand Cam
- Relief in Dwell for shot-pin applications

50RGD/50RGS SERIES

Roller Gear Index Drive | Dimensions

50RGD

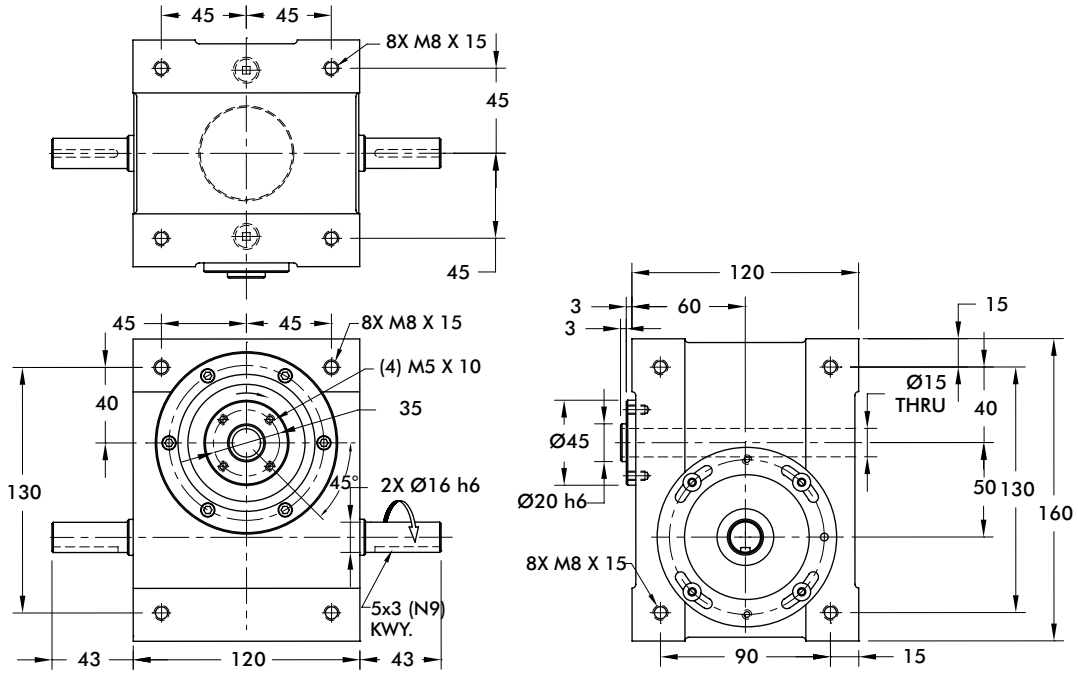

50RGS

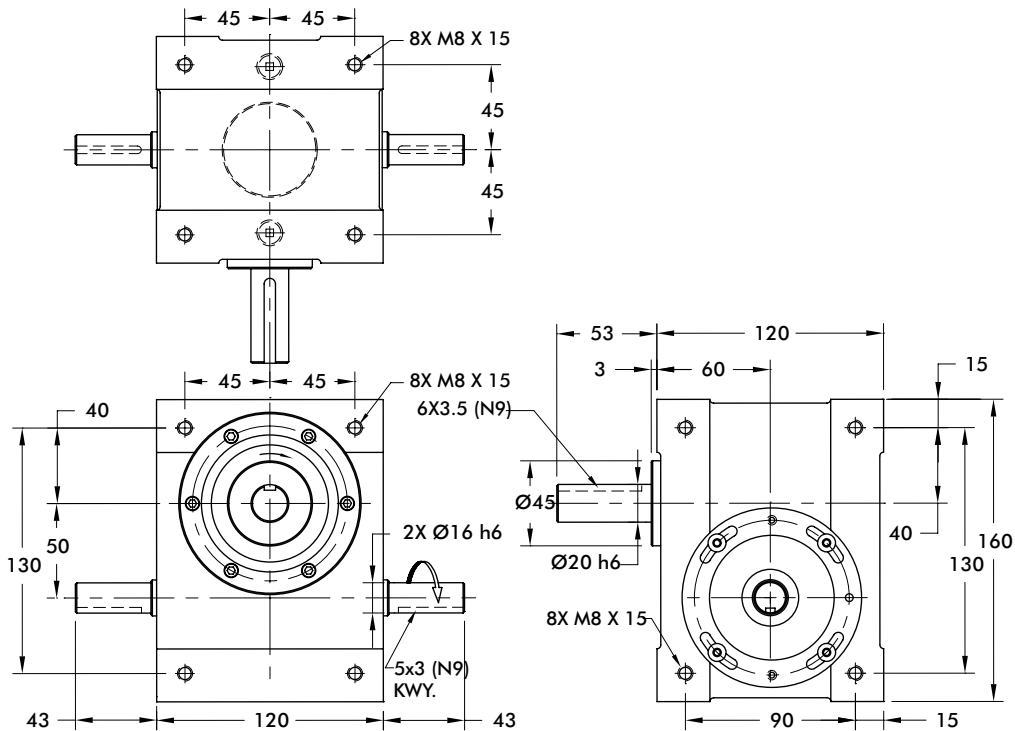

Unless otherwise noted,
all dimensions are in mm.

50RGD/50RGS SERIES

Roller Gear Index Drive | Features | Optional Accessories | Technical Information

50RGD/50RGS Indexer Capacities						
Stops	Index Period	Motion	B ₁₀ Capacity at 50 RPM (in-lb)	RGD Internal Inertia (lb-in ²)	RGS Internal Inertia (lb-in ²)	Model
2	270	msc.50	621	1.4	1.6	50RG(D/S)2H18-270
3	270	ms	287	1.3	1.5	50RG(D/S)3H14-270
	180	ms	300	1.3	1.5	50RG(D/S)3H14-180
4	270	ms	326	1.4	1.5	50RG(D/S)4H14-270
	180	ms	351	1.4	1.5	50RG(D/S)4H14-180
6	270	ms	606	1.4	1.6	50RG(D/S)6H18-270
	90	ms	734	1.4	1.6	50RG(D/S)6H18-90
8	270	ms	336	1.4	1.5	50RG(D/S)8H14-270
	90	ms	403	1.4	1.5	50RG(D/S)8H14-90
12	270	ms	275	1.4	1.5	50RG(D/S)12H12-270
	90	ms	329	1.4	1.5	50RG(D/S)12H12-90
16	180	ms	447	1.4	1.5	50RG(D/S)16H14-180 II
24	180	ms	374	1.4	1.5	50RG(D/S)24H12-180 II
	120	ms	409	1.4	1.5	50RG(D/S)24H12-120 II

Other Motions (stops and index periods) available. Contact your DESTACO sales representative for more information.

Features

- Fully Metric
- Universal Mounting: mounting holes on any of 6 sides
- Center Through Hole (.59 in./15 mm Diameter) in RGD model.
- Right Hand Cam

Output Load Capacity (loads carried during index):

	RGD	RGS
Radial	1,775 lbs	379 lbs
Thrust/Axial	925 lbs	545 lbs
Moment	1,572 in-lb	791 in-lb

Accuracy ±73 arcsec / ±.0011" at 3" Radius

Repeatability ±18 arcsec / ±.0003" at 3" Radius

Optional Accessories

- R180 Reducer (Ratios from 15:1 to 60:1)
 - Double Extended Worm Shaft (Input)
 - Worm Shaft Handwheel
- 1/3 hp AC Drive Package with Inverter Duty Motor and IM-pAC AC Drive (up to 60 cpm)
- Cycle Cam and Limit Switch Mounted to Camshaft
- Right Hand Cam
- Universal Mounting Capability

70RGD/70RGS SERIES

Roller Gear Index Drive | Dimensions

70RGD

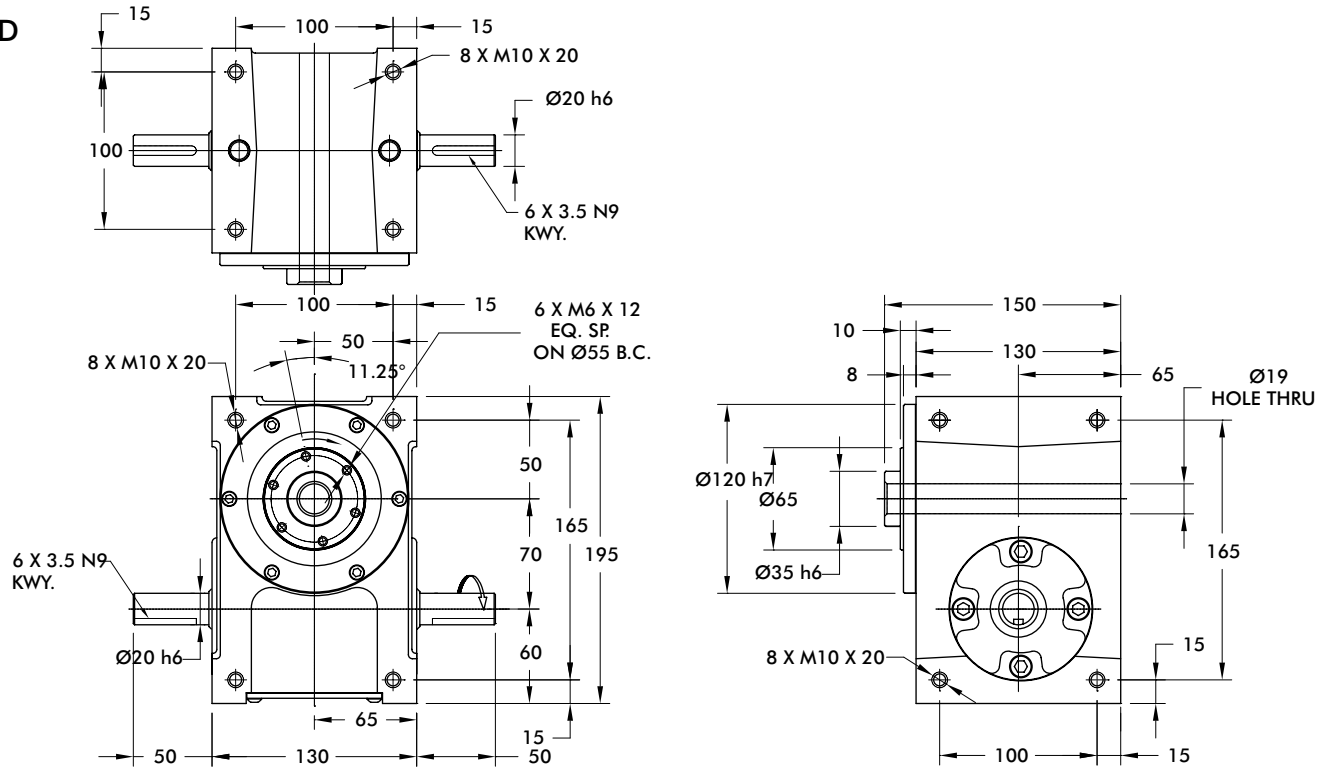

70RGS

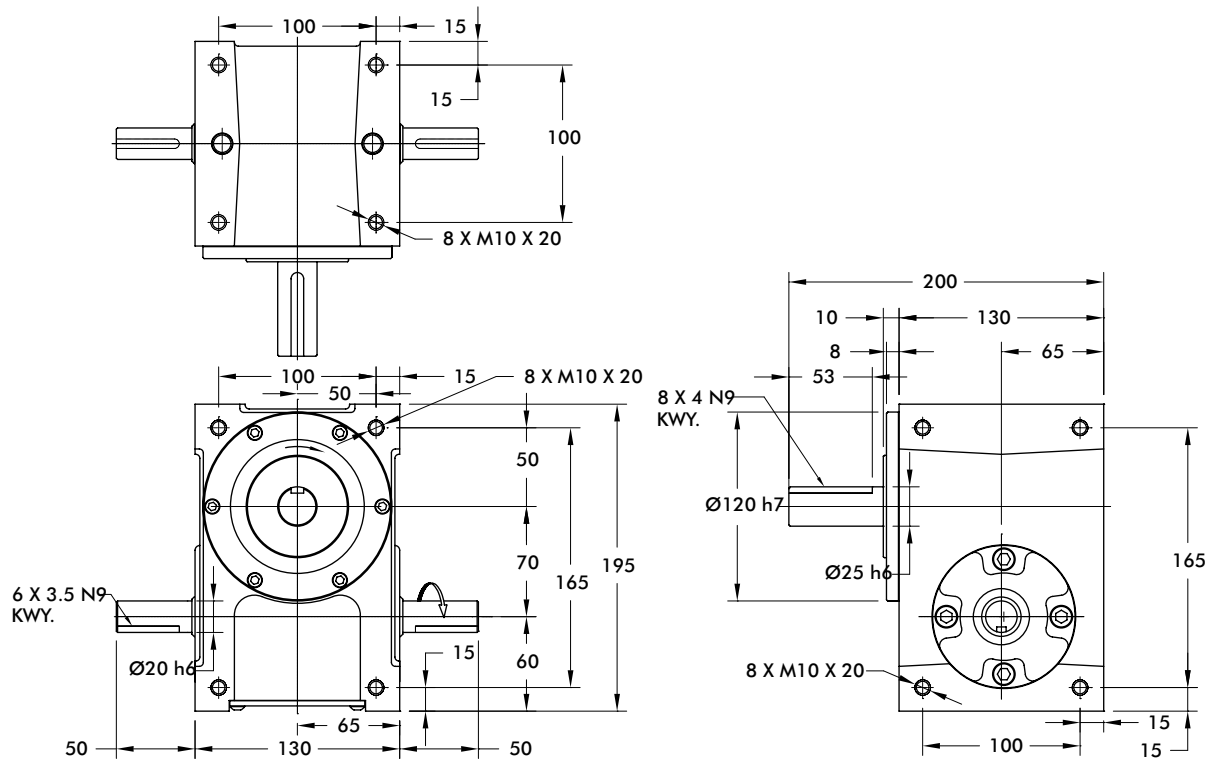

70RGD/70RGS



Unless otherwise noted,
all dimensions are in mm.

70RGD/70RGS SERIES

Roller Gear Index Drive | Features | Optional Accessories | Technical Information

70RGD/70RGS Indexer Capacities						
Stops	Index Period	Motion	B ₁₀ Capacity at 50 RPM (in-lb)	RGD Internal Inertia (lb-in ²)	RGS Internal Inertia (lb-in ²)	Model
2	270	ms	585	7	8	70RG(D/S)2H20-270
	180	ms	562	7	8	70RG(D/S)2H18-180
3	270	ms	720	7	8	70RG(D/S)3H20-270
	180	ms	753	7	8	70RG(D/S)3H20-180
4	270	ms	821	9	10	70RG(D/S)4H20-270
	120	msc.33	1107	10	10	70RG(D/S)4H18-120
6	270	ms	1406	9	10	70RG(D/S)6H24-270
	90	msc.33	2110	9	10	70RG(D/S)6H24-90
8	270	ms	853	9	10	70RG(D/S)8H20-270
	90	ms	1063	9	10	70RG(D/S)8H20-90
12	270	ms	470	10	10	70RG(D/S)12H14-270
	90	ms	584	10	10	70RG(D/S)12H14-90
24	180	ms	635	10	10	70RG(D/S)24H14-180 II

Other Motions (stops and index periods) available. Contact your DESTACO sales representative for more information.

Features

- Fully Metric
- Universal Mounting: mounting holes on any of 6 sides
- Center Through Hole (.75 in./19 mm Diameter) in RGD model.
- Right Hand Cam

Output Load Capacity (loads carried during index):

	RGD	RGS
Radial	2,833 lbs	560 lbs
Thrust/Axial	2,224 lbs	802 lbs
Moment	3,626 in-lb	1,545 in-lb

Accuracy ±50 arcsec / ±.0008" at 3" Radius

Repeatability ±13 arcsec / ±.0002" at 3" Radius

Optional Accessories

- R180 Reducer (Ratios from 5:1 to 60:1)
- 1/3 hp AC Drive Package with Inverter Duty Motor and Inverter Drive (up to 60 cpm)
- 1/3 hp DC Motor with Varipak DC Motor Control (up to 30 cpm)
- Single or Dual Cycle Cam and Limit Switch
- Left Hand Cam
- Relief in Dwell for shot-pin applications

80RGD/80RGS SERIES

Roller Gear Index Drive | Dimensions

80RGD

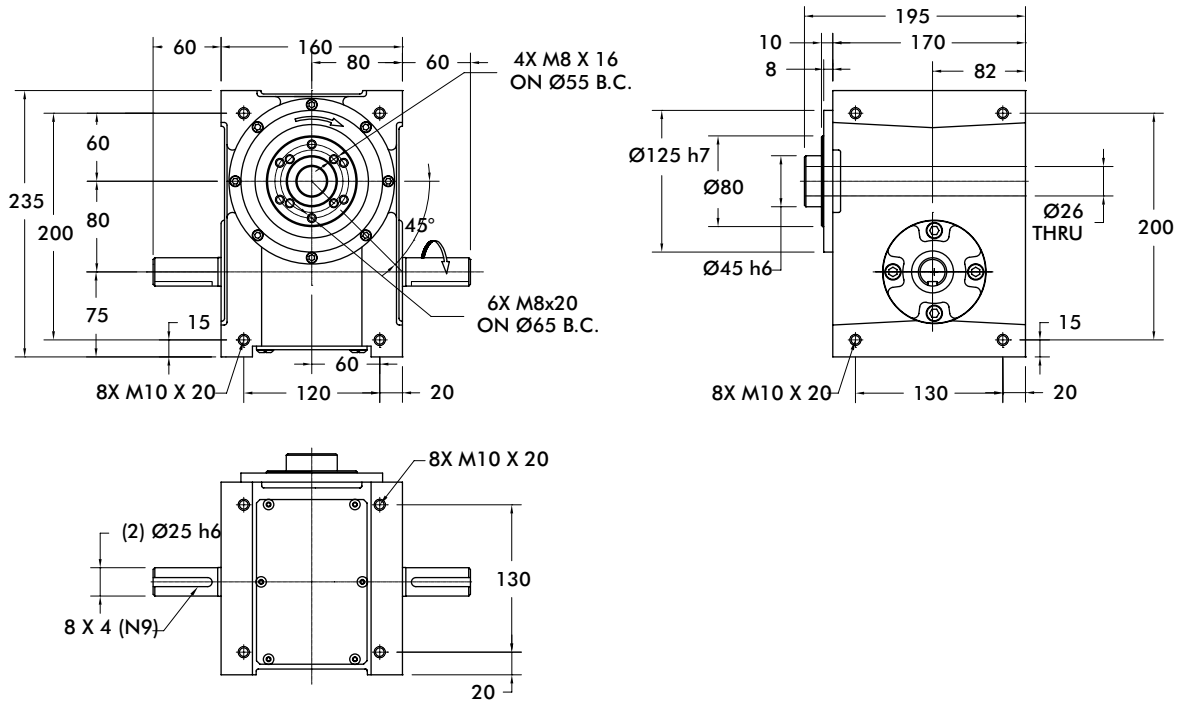

80RGS

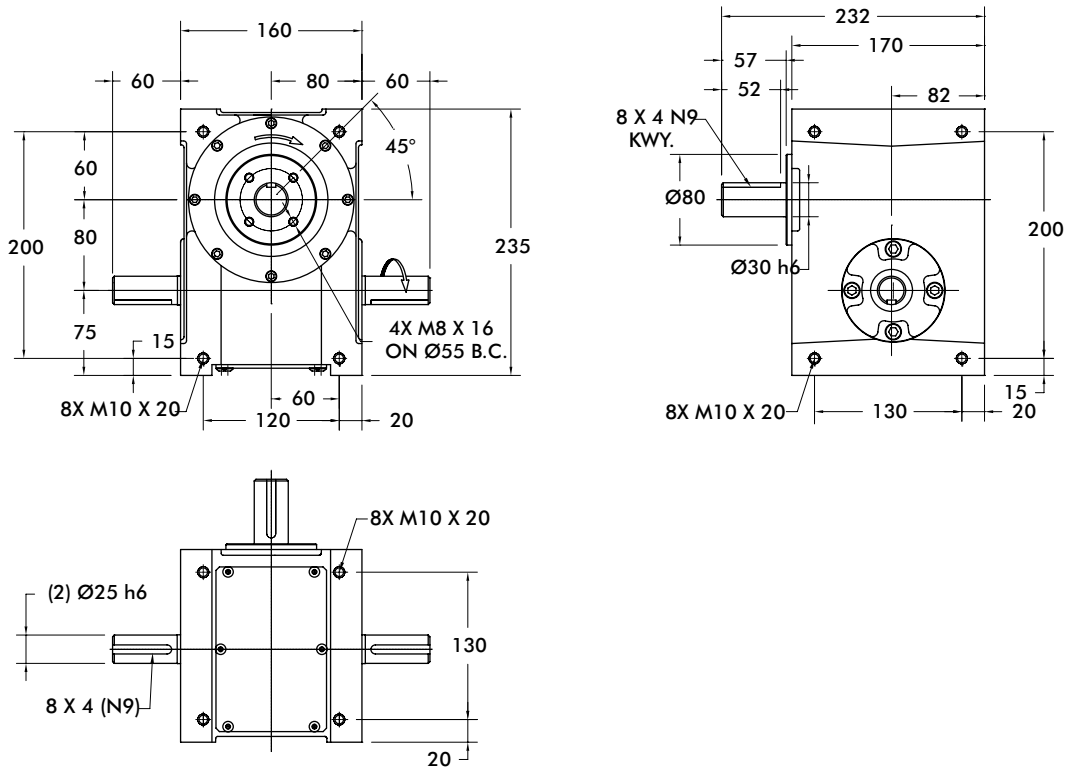

Unless otherwise noted,
all dimensions are in mm.

80RGD/80RGS SERIES

Roller Gear Index Drive | Features | Optional Accessories | Technical Information

80RGD/80RGS Indexer Capacities						
Stops	Index Period	Motion	B ₁₀ Capacity at 50 RPM (in-lb)	RGD Internal Inertia (lb-in ²)	RGS Internal Inertia (lb-in ²)	Model
2	330	ms	1144	16	17	80RG(D/S)2H24-330
	270	msc.33	1388	16	17	80RG(D/S)2H24-270
3	270	ms	1422	16	17	80RG(D/S)3H24-270
	180	ms	1513	16	17	80RG(D/S)3H24-180
4	270	ms	1663	21	21	80RG(D/S)4H24-270
	180	msc.33	2377	21	21	80RG(D/S)4H24-180
6	270	ms	1524	18	19	80RG(D/S)6H28-270
	90	msc.50	2323	18	19	80RG(D/S)6H28-90
8	270	ms	1733	21	21	80RG(D/S)8H24-270
	90	msc.33	2937	21	21	80RG(D/S)8H24-90
12	270	ms	1011	20	20	80RG(D/S)12H18-270
	90	msc.60	1725	20	20	80RG(D/S)12H18-90

Other Motions (stops and index periods) available. Contact your DESTACO sales representative for more information.

Features

- Fully Metric
- Universal Mounting: mounting holes on any of 6 sides
- Center Through Hole (1.02 in./26 mm Diameter) in RGD model.
- Right Hand Cam

Output Load Capacity (loads carried during index):

	RGD	RGS
Radial	4,790 lbs	1,189 lbs
Thrust/Axial	3,470 lbs	1,246 lbs
Moment	7,544 in-lb	2,669 in-lb
Accuracy	±48 arcsec / ±.0007" at 3" Radius	
Repeatability	±12 arcsec / ±.0002" at 3" Radius	

Optional Accessories

- R180 Reducer (Ratios from 5:1 to 60:1)
- 1/3 hp AC Drive Package with Inverter Duty Motor and Inverter Drive (up to 60 cpm)
- 1/3 hp DC Motor with Varipak DC Motor Control (up to 30 cpm)
- Single or Dual Cycle Cam and Limit Switch
- Left Hand Cam
- Relief in Dwell for shot-pin applications

110RGD/110RGS SERIES

Roller Gear Index Drive | Dimensions

110RGD

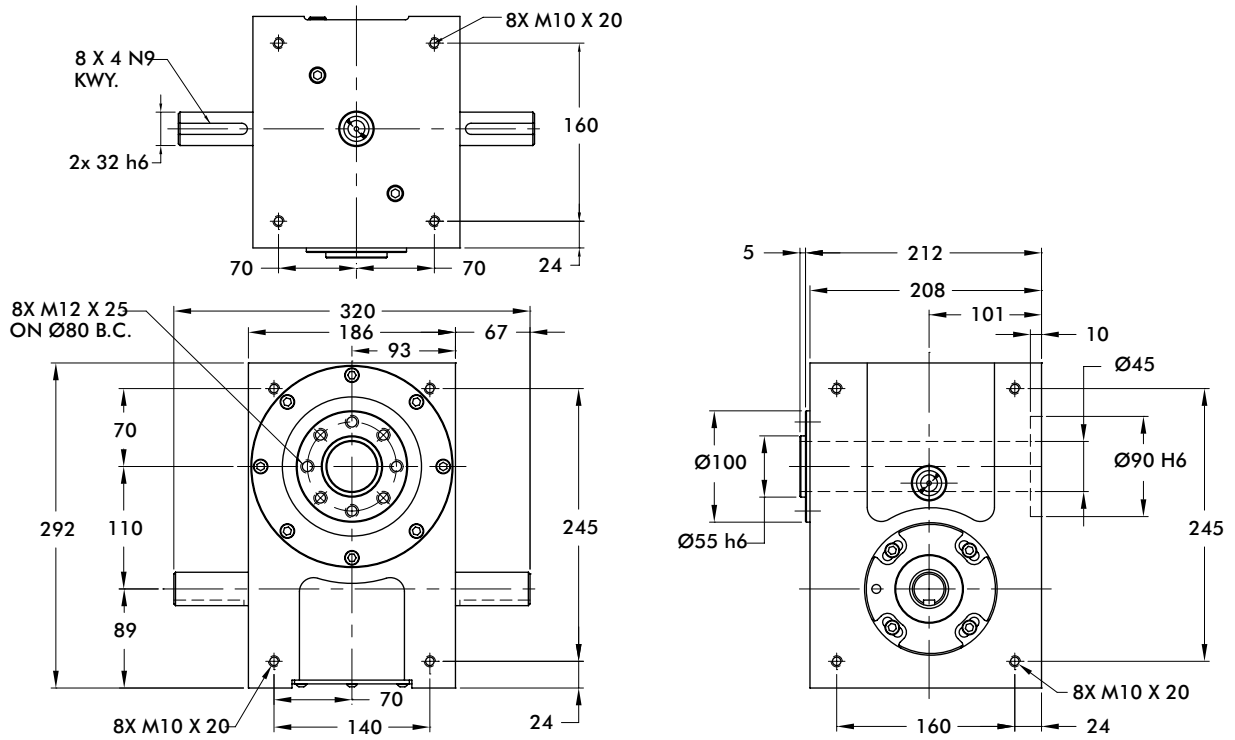

110RGS

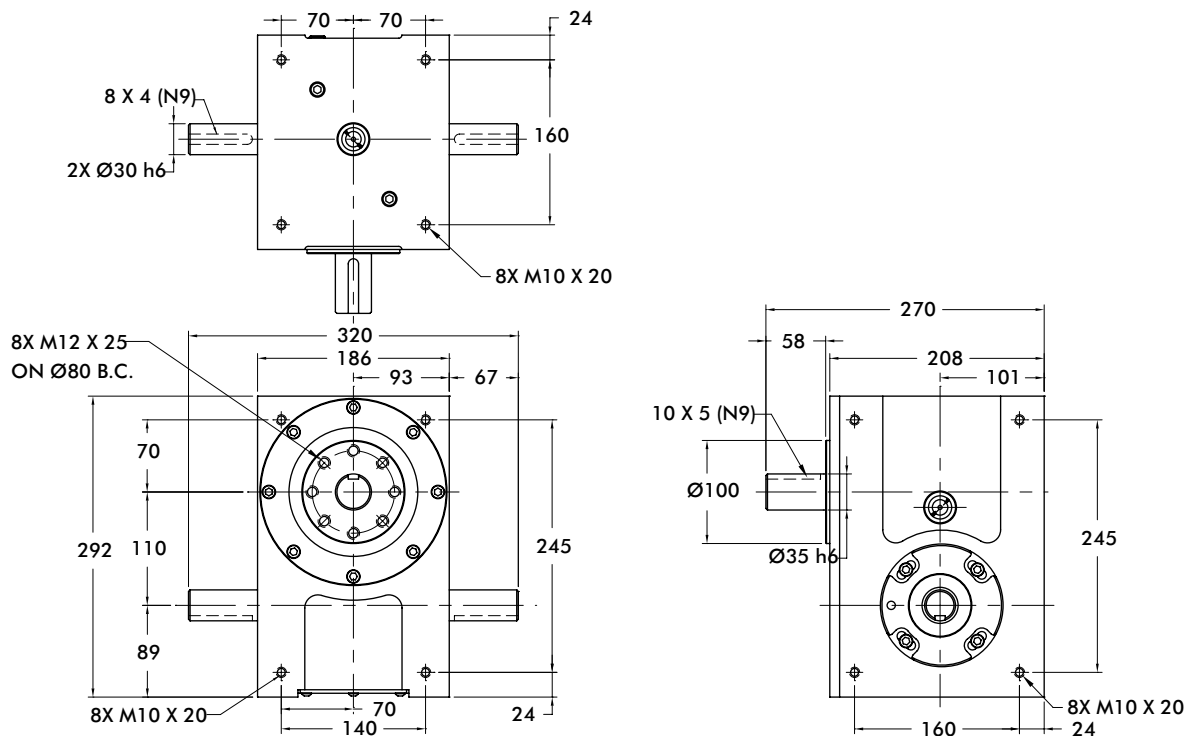

Unless otherwise noted,
all dimensions are in mm.

110RGD/110RGS SERIES

Roller Gear Index Drive | Features | Optional Accessories | Technical Information

110RGD/110RGS Indexer Capacities						
Stops	Index Period	Motion	B ₁₀ Capacity at 50 RPM (in-lb)	RGD Internal Inertia (lb-in ²)	RGS Internal Inertia (lb-in ²)	Model
2	300	msc.33	5271	51	56	110RG(D/S)2H40-300
	270	msc.50	6126	51	56	110RG(D/S)2H40-270
3	270	ms	5609	51	56	110RG(D/S)3H40-270
	180	msc.50	7829	51	56	110RG(D/S)3H40-180
4	270	ms	3282	48	55	110RG(D/S)4H32-270
	180	msc.33	4147	48	55	110RG(D/S)4H32-180
6	270	ms	7378	52	70	110RG(D/S)6H48-270
	120	msc.33	8127	51	56	110RG(D/S)6H40-120
8	270	ms	3440	48	55	110RG(D/S)8H32-270
	120	ms	4149	48	55	110RG(D/S)8H32-120
12	270	ms	2815	47	55	110RG(D/S)12H28-270
	120	ms	3367	45	51	110RG(D/S)12H24-120
16	270	ms	1610	45	53	110RG(D/S)16H20-270
	120	ms	1992	45	53	110RG(D/S)16H20-120
24	270	ms	3650	45	51	110RG(D/S)24H24-270 II
	180	ms	4134	45	51	110RG(D/S)24H24-180 II

Other Motions (stops and index periods) available. Contact your DESTACO sales representative for more information.

Features

- Fully Metric
- Universal Mounting: mounting holes on any of 6 sides
- Center Through Hole (1.77 in./45 mm Diameter) in RGD model.
- Right Hand Cam

Output Load Capacity (loads carried during index):

	RGD	RGS
Radial	5,613 lbs	1,856 lbs
Thrust/Axial	4,411 lbs	2,053 lbs
Moment	11,050 in-lb	4,238 in-lb

Accuracy ±30 arcsec / ±.0009" at 6" Radius

Repeatability ±8 arcsec / ±.0002" at 6" Radius

Optional Accessories

- KH37 Reducer
 - Ratios from 5.36:1 to 106.38:1 (consult factory for exact ratios available)
 - 1 hp AC Drive Package with Inverter Duty Motor and Inverter Drive (up to 60 cpm)
- Single or Dual Cycle Cam and Limit Switch
- Left Hand Cam
- Relief in Dwell for shot-pin applications

350RGD/350RGS SERIES

Roller Gear Index Drive | Dimensions

350RGD

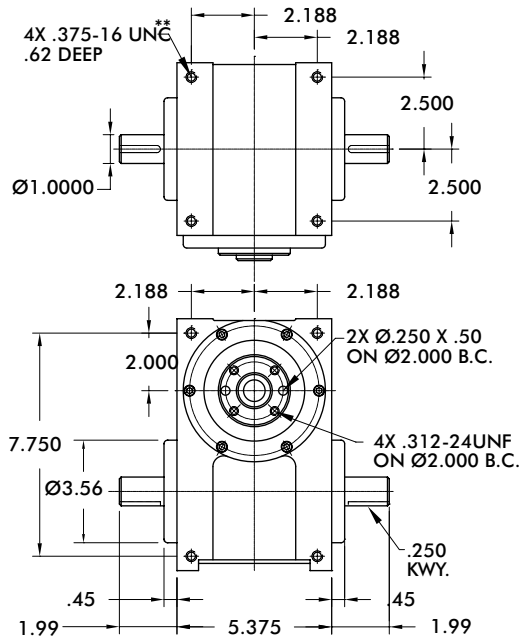

** 4 TAPPED MOUNTING HOLES IN ANY ONE OF SIX FINISHED SIDES, TO BE SPECIFIED BY CUSTOMER

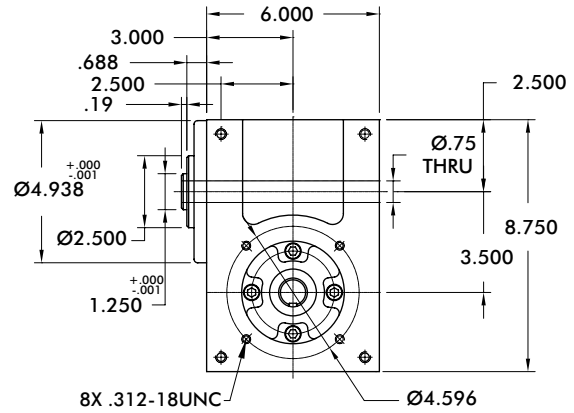

350RGS

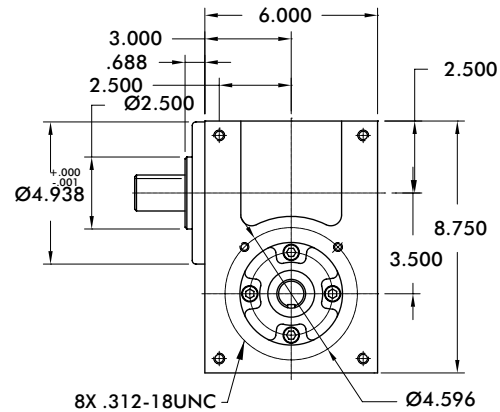
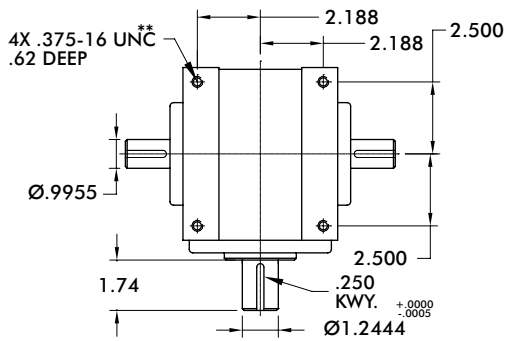

Unless otherwise noted,
all dimensions are in mm.

350RGD/350RGS SERIES

Roller Gear Index Drive | Features | Optional Accessories | Technical Information

350RGD/350RGS Indexer Capacities						
Stops	Index Period	Motion	B ₇₀ Capacity at 50 RPM (in-lb)	RGD Internal Inertia (lb-in ²)	RGS Internal Inertia (lb-in ²)	Model
1	330	msc.50	1774	7.7	9.7	350RG(D/S)1H24-330
2	270	ms	1244	7.7	9.7	350RG(D/S)2H24-270
	180	msc.67	2047	7.7	9.7	350RG(D/S)2H24-180
3	270	ms	1530	7.7	9.7	350RG(D/S)3H24-270
	180	ms	1601	7.7	9.7	350RG(D/S)3H24-180
4	300	ms	1701	8.1	10.1	350RG(D/S)4H24-300
	180	ms	2001	8.1	10.1	350RG(D/S)4H24-180
6	270	ms	1615	7.7	9.7	350RG(D/S)6H24-270
	90	ms	2063	7.7	9.7	350RG(D/S)6H24-90
8	270	ms	1840	8.1	10.1	350RG(D/S)8H24-270
	90	ms	2716	8.1	10.1	350RG(D/S)8H24-90
12	270	ms	1132	7.9	9.9	350RG(D/S)12H20-270
	90	ms	1476	7.9	9.9	350RG(D/S)12H20-90

Other Motions (stops and index periods) available. Contact your DESTACO sales representative for more information.

Features

- Universal Mounting: mounting holes on any of 6 sides
- Center Through Hole (.75 in. Diameter) in RGD model.
- Right Hand Cam Standard

Output Load Capacity (loads carried during index):

	RGD	RGS
Radial	1,935 lbs	1,808 lbs
Thrust/Axial	1,406 lbs	786 lbs
Moment	2,419 in-lb	3,164 in-lb

Accuracy ±41 arcsec / ±.0012" at 6" Radius

Repeatability ±10 arcsec / ±.0003" at 6" Radius

Optional Accessories

- R180 Reducer (Ratios from 5:1 to 60:1)
 - 1/3 hp AC Drive Package with Inverter Duty Motor and Inverter Drive (up to 60 cpm)
 - 1/3 hp DC Motor with Varipak DC Motor Control (up to 30 cpm)
- R225 Reducer (Ratios from 5:1 to 60:1)
 - 56C Motor Adapter and Coupling
 - 1 hp AC Drive Package with Inverter Duty Motor and Inverter Drive (up to 60 cpm)
 - 1 hp DC Motor with Varipak DC Motor Control (up to 30 cpm)
- Single or Dual Cycle Cam and Limit Switch
- Relief in Dwell for shot-pin applications
- Left Hand Cam
- Relief in Dwell for shot-pin applications

500RGD/500RGS SERIES

Roller Gear Index Drive | Features | Optional Accessories | Technical Information

500RGD/500RGS Indexer Capacities						
Stops	Index Period	Motion	B ₁₀ Capacity at 50 RPM (in-lb)	RGD Internal Inertia (lb-in ²)	RGS Internal Inertia (lb-in ²)	Model
1	330	msc.60	6767	62	45	500RG(D/S)1H40-330
2	270	ms	4400	62	45	500RG(D/S)2H40-270
3	270	ms	5265	62	45	500RG(D/S)3H40-270
	180	ms	5706	62	45	500RG(D/S)3H40-180
4	270	ms	6121	66	48	500RG(D/S)4H40-270
	120	msc.20	3892	60	42	500RG(D/S)4H32-120
6	270	ms	5464	62	45	500RG(D/S)6H40-270
	90	ms	6909	62	45	500RG(D/S)6H40-90
8	270	ms	6151	66	48	500RG(D/S)8H40-270
	90	ms	8219	66	48	500RG(D/S)8H40-90
12	270	ms	2616	58	40	500RG(D/S)12H28-270
	90	ms	3449	58	40	500RG(D/S)12H28-90

Other Motions (stops and index periods) available. Contact your DESTACO sales representative for more information.

Features

- Universal Mounting: mounting holes on any of 6 sides
- Center Through Hole (1.50 in. Diameter) in RGD model.
- Right Hand Cam Standard

Output Load Capacity (loads carried during index):

	RGD	RGS
Radial	4,004 lbs	3,767 lbs
Thrust/Axial	2,759 lbs	1,433 lbs
Moment	8,509 in-lb	12,959 in-lb

Accuracy ±29 arcsec / ±.0008" at 6" Radius

Repeatability ±7 arcsec / ±.0002" at 6" Radius

Optional Accessories

- R225 Reducer (Ratios from 5:1 to 60:1)
 - 1 hp AC Drive Package with Inverter Duty Motor and Inverter Drive (up to 60 cpm)
 - 1 hp DC Motor with Varipak DC Motor Control (up to 30 cpm)
- Single or Dual Cycle Cam and Limit Switch
- Output Overload Clutch Models: 11S, 11C, 11F, 11C-SD, 11S-SD, 11FC-SD
 - Available Settings (in-lbs): 2300, 4000, 6000, 8500, 11000
- Left Hand Cam
- Relief in Dwell for shot-pin applications
- Left Hand Cam

600RGD/600RGS SERIES

Roller Gear Index Drive | Dimensions

600RGD

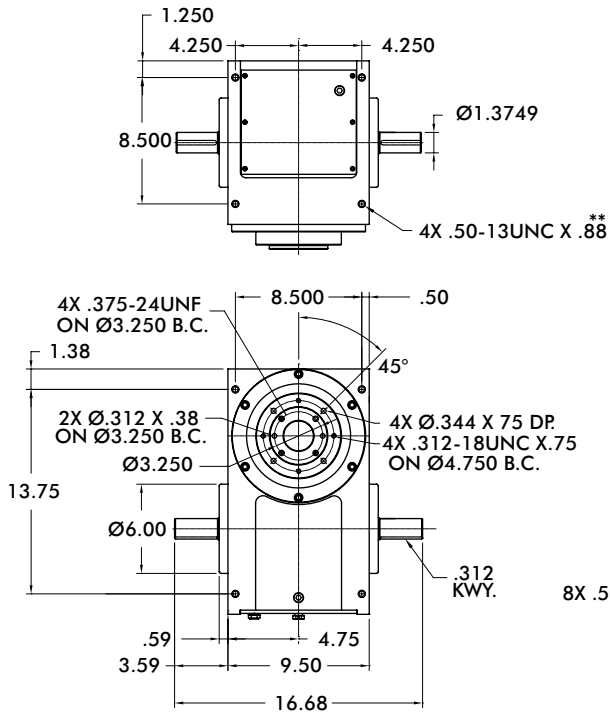

** 4 TAPPED MOUNTING HOLES IN ANY ONE OF SIX FINISHED SIDES, TO BE SPECIFIED BY CUSTOMER

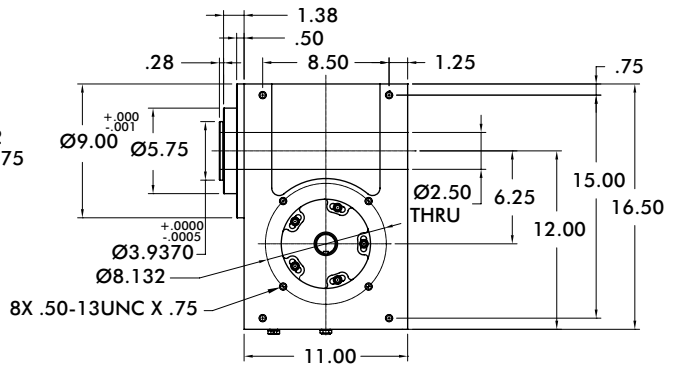

600RGS

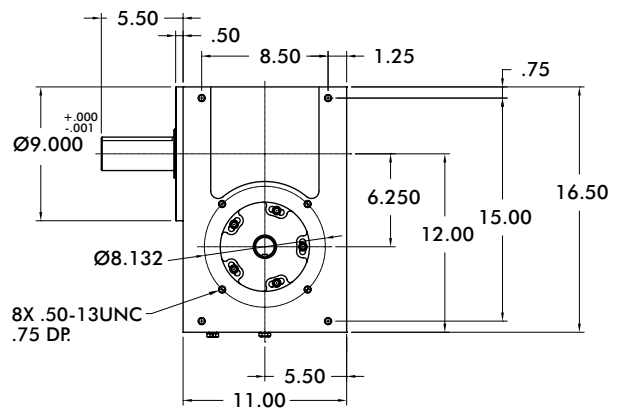
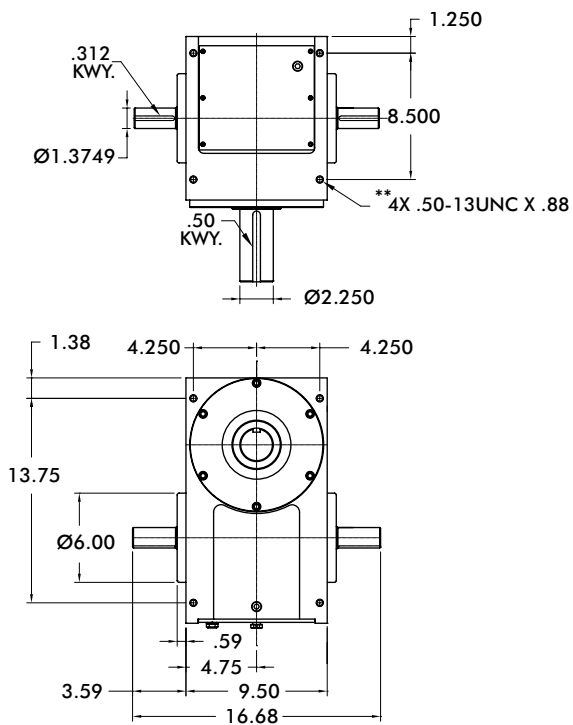

Unless otherwise noted,
all dimensions are in mm.

600RGD/600RGS SERIES

Roller Gear Index Drive | Features | Optional Accessories | Technical Information

600RGD/600RGS Indexer Capacities						
Stops	Index Period	Motion	B ₁₀ Capacity at 50 RPM (in-lb)	RGD Internal Inertia (lb-in ²)	RGS Internal Inertia (lb-in ²)	Model
2	300	ms	6516	256	137	600RG(D/S)2H48-300
3	270	ms	7955	256	137	600RG(D/S)3H48-270
	180	ms	8769	256	137	600RG(D/S)3H48-180
4	270	ms	6749	249	131	600RG(D/S)4H40-270
	180	ms	7477	249	131	600RG(D/S)4H40-180
6	270	ms	8286	256	137	600RG(D/S)6H48-270
	90	ms	10715	256	137	600RG(D/S)6H48-90
8	270	ms	6928	244	126	600RG(D/S)8H40-270
	90	ms	8936	244	126	600RG(D/S)8H40-90
12	270	ms	4091	244	126	600RG(D/S)12H32-270
	90	ms	5444	244	126	600RG(D/S)12H32-90
16	270	ms	9553	249	131	600RG(D/S)16H40-270 II
	90	ms	12224	249	131	600RG(D/S)16H40-90 II

Other Motions (stops and index periods) available. Contact your DESTACO sales representative for more information.

Features

- Universal Mounting: mounting holes on any of 6 sides
- Center Through Hole (2.50 in. Diameter) in RGD model.
- Right Hand Cam Standard

Output Load Capacity (loads carried during index):

	RGD	RGS
Radial	5,667 lbs	3,828 lbs
Thrust/Axial	3,528 lbs	3,529 lbs
Moment	16,292 in-lb	18,451 in-lb

Accuracy ±40 arcsec / ±.0011" at 6" Radius

Repeatability ±10 arcsec / ±.0003" at 6" Radius

Optional Accessories

- 7300C or 7350C Reducer (Ratios from 5:1 to 60:1)
- 1 or 2 hp AC Drive Package with Inverter Duty Motor and Inverter Drive (up to 60 cpm)
- 1 or 2 hp DC Motor with Varipak DC Motor Control (up to 30 cpm)
- Single or Dual Cycle Cam and Limit Switch
- Output Overload Clutch Models: 11FM, 11SM
– Available Settings (in-lbs): 2300, 4000, 6000, 8500, 11000
- Left Hand Cam
- Relief in Dwell for shot-pin applications
- Left Hand Cam